

Panasonic

BUSINESS

Semi-Hermetic Reciprocating Compressor For Refrigeration



Panasonic Appliances Refrigeration System(Dalian)Co.,Ltd.

Semi-Hermetic Reciprocating Compressor For Refrigeration

INDEX

1.Features of Panasonic semi-hermetic reciprocating compressor	1
2.Semi-hermetic compressor standard rating conditions	2
3.Semi-hermetic compresor series / Model number nomenclatures	3
4.Semi-hermetic compressor application stardard & Limit	4 ~ 5
5.Technical Specif.	6 ~ 17
6.Performance Data	18 ~ 29
7.Outline graph	30 ~ 33

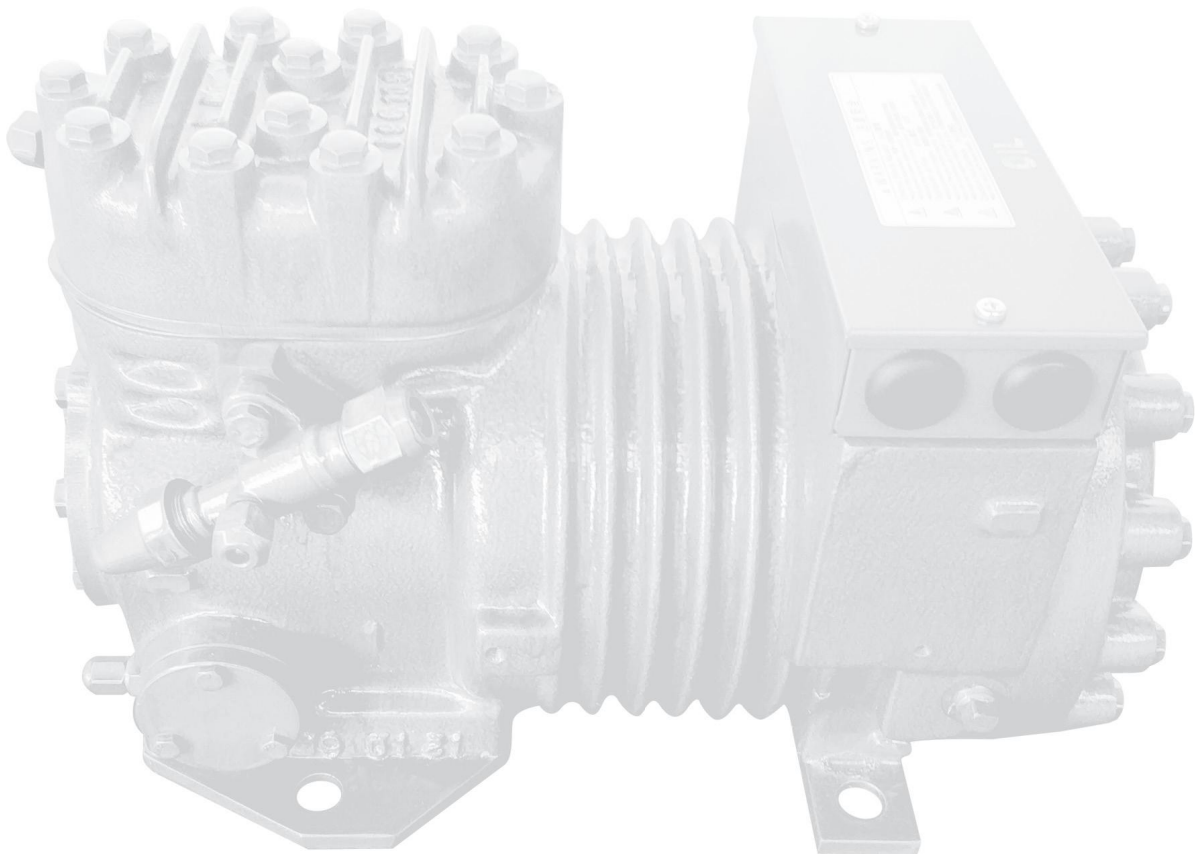

Semi-Hermetic Reciprocating Compressor For Refrigeration

R22
R404A

FEATURES OF **Panasonic** SEMI-HERMETIC RECIPROCATING COMPRESSOR

1 ← High Reliability, Durable Performance

- ※ Stable performance with many patent design.
- ※ Long-tested quality, 15 years service life.

2 ← Environmentl Friendly Refrigerant, Green Product

- ※ Use environmental friendly refrigerant R22 or R404A.
- ※ All spare parts are of ROHS environmental stardard.

3 ← Wide Range of Evaparating Temp.

- ※ Work at -5C~-40C using refrigerant R22
- ※ Work at -5C~-45C using refrigerant R404A

4 ← Large Capacity

- ※ Minimum gap-volume
- ※ High efficiency elctrical motor

5 ← Long-lasting Parts

- ※ Brass Bushing of toggle in brass-alley
- ※ The long-lasting resin ring for the piston
- ※ Harden treatment for crank surface

6 ← Low Sound Level, Low Vibration

- ※ Light quality piston connecting rode to accomplish quiet operation
- ※ The crank rotor total dynamic balance test quarantees the vibration to be smallest.

7 ← Electrical Protective Device

- ※ Electrical machinery hot protective device monitoring the ele. machinery.

8 ← Reliable Lubrication

- ※ Flashing lubrication
- ※ Oil pump lubrication

9 ← Crankcase Heater (optional)

- ※ Jack-in type
- ※ Prevent liquid-flood-back effectively

Semi-Hermetic Reciprocating Compressor For Refrigeration

R22
R404A

Semi-hermetic Compressor Application Range (R22)

Semi-hermetic Compressor Application Range (R22)
2.2kW ~ 5.5kW Suction Temp.: 18.3 C

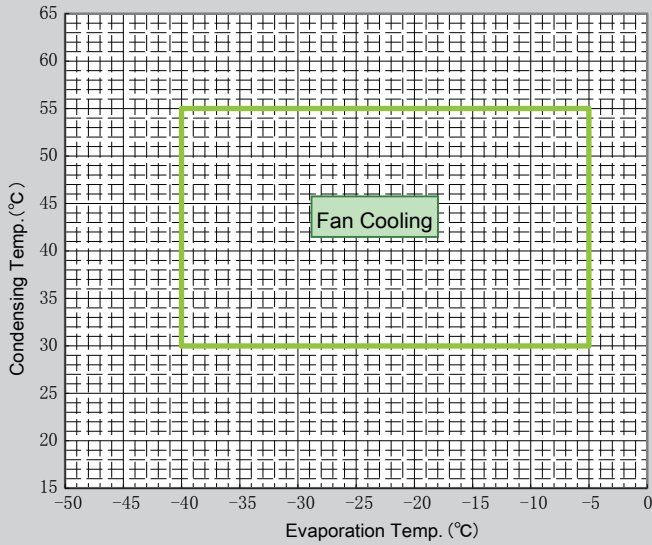

Semi-hermetic Compressor Application Range (R22)
7.5kW ~ 15kW Suction Temp.: 18.3 C

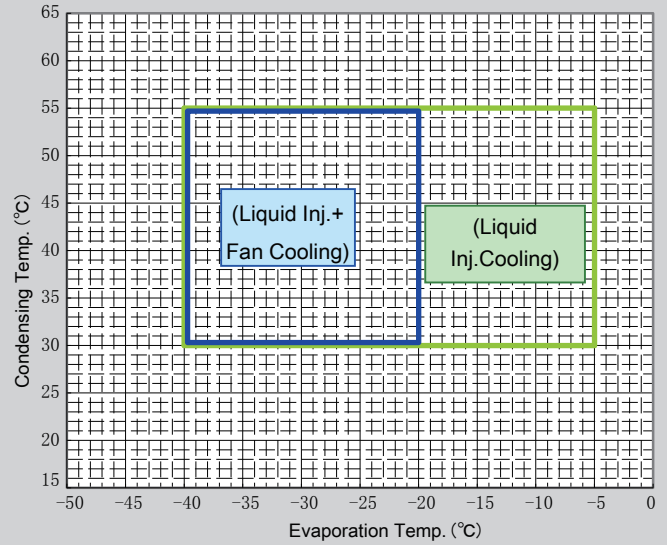

Semi-hermetic Compressor Application Range (R404A)

Semi-hermetic Compressor Application Range (R404A)
2.2kW ~ 5.5kW Suction Temp.: 18.3 C

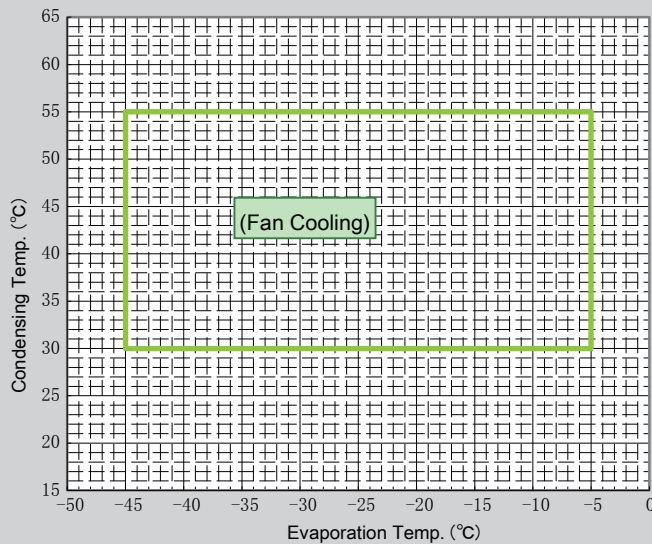

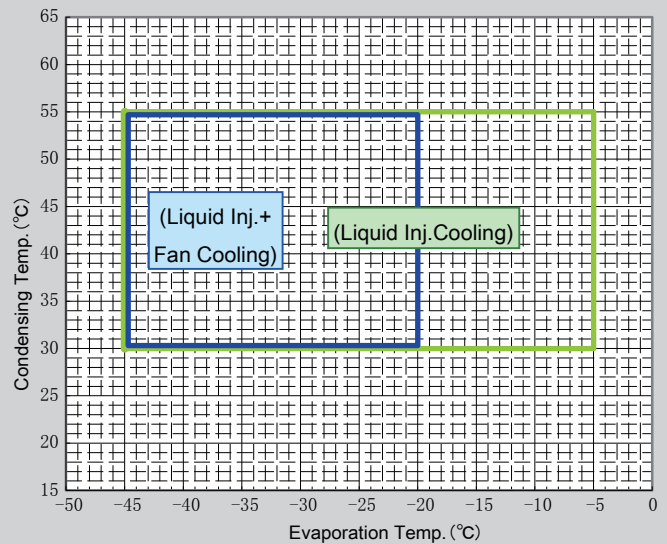

Semi-hermetic Compressor Application Range (R404A)
7.5kW ~ 15kW Suction Temp.: 18.3 C



Semi-Hermetic Reciprocating Compressor For Refrigeration

R22
R404A

Semi-hermetic Compressor series

Series	Nominal Output		Compressor Model Compressor Code						
			Refrigerant R22			Refrigerant R404A			
			50Hz380-415V 60Hz440V	60Hz380V	50Hz200V 60Hz200-220V	50Hz380-415V 60Hz440V	60Hz380V	50Hz200V 60Hz200-220V	
 CL1	1.5kw 2HP	Mode	C-L15M8H	---	C-L15M3E	C-LN15M8A	---	C-LN15M3A	
		Code	805 030 68	---	805 025 63	805 060 68	---	805 060 63	
	2.2 kw 3 HP	Mode	C-L22M8F	C-L22M9C	C-L22M3B	C-LN22M8A	C-LN22M9A	C-LN22M3A	
		Code	805 046 68	805 042 69	805 041 63	805 047 68	805 047 69	805 047 63	
 CL2	2.8 kw 4 HP	Mode	C-L28M8G	---	C-L28M3E	C-LN28M8A	---	C-LN28M3A	
		Code	805 139 68	---	805 137 63	805 140 68	---	805 140 63	
	3.7 kw 5 HP	Mode	C-L37M8L	C-L37M9H	C-L37M3J	C-LN37M8A	C-LN37M9A	C-LN37M3A	
		Code	805 343 68	805 340 69	805 341 63	805 344 68	805 344 69	805 344 63	
	4.5 kw 6 HP	Mode	C-L45M8D	---	C-L45M3C	C-LN45M8A	---	C-LN45M3A	
		Code	805 533 68	---	805 532 63	805 535 68	---	805 535 63	
	5.5 kw 7.5 HP	Mode	C-L55M8E	C-L55M9D	C-L55M3C	C-LN55M8A	C-LN55M9A	C-LN55M3A	
		Code	805 444 68	805 442 69	805 440 63	805 445 68	805 445 69	805 445 63	
	 CL3	7.5 kw 10 HP	Mode	C-L75M8I	C-L75M9I	C-L75M3I	C-LN75M8I	C-LN75M9I	C-LN75M3I
			Code	805 731 68	805 731 69	805 731 63	805 737 68	805 737 69	805 737 63
		9 kw 12.5 HP	Mode	C-L90M82	---	C-L90M3I	C-LN90M8I	---	C-LN90M3I
			Code	805 742 68	---	805 740 63	805 741 68	---	805 741 63
10.5 kw 15 HP		Mode	C-L105M83	C-L113M9I	C-L105M3I	C-LN105M8I	C-LN113M9I	C-LN105M3I	
		Code	805 840 68	805 831 69	805 831 63	805 838 68	805 838 69	805 838 63	
15 kw 20 HP		Mode	C-L150M82	C-L150M9I	C-L150M3I	C-LN150M8I	C-LN150M9I	C-LN150M3I	
		Code	805 934 68	805 931 69	805 931 63	805 933 68	805 933 69	805 933 63	

Model Nomenclatures

C-L N 15 M 8 H

Design Code	-		
Power Source Type	8	50Hz	380 - 415 V
		60 Hz	440 V
	9	60 Hz	380V
		50 Hz	200 V
Application	M	medium – low temp	
		low temp	
Power Output	15	1.5 kw	2HP
	22	2.2 kw	3 HP
	28	2.8 kw	4 HP
	37	3.7 kw	5 HP
	45	4.5 kw	6 HP
	55	5.5 kw	7.5 HP
	75	7.5 kw	10 HP
	90	9.0 kw	12.5 HP
	105	10.5 kw	15 HP
Refrigerant	N	R404A	
	ellipsis	R22	
Compressor type	Semi-Hermetic Reciprocating Compressor For Refrigeration		

Semi-Hermetic Reciprocating Compressor For Refrigeration

Semi-hermetic compressor application standard & Limit (R22)

The following instructions apply to semi-hermetic compressor:

- Apply to ordinary conditions.
- Apply to transitional short period of operation, such as start-up and defrost mode.

No	Item	Standard	Limit	Notes
1	Refrigerant	R22		
2	Eevap. Temp.	-40 ~ -5°C (0.004 ~ 0.326MPa(G))		Compressor suction pressure
3	Cond. Temp.	+30 ~ +55°C (1.089 ~ 2.069MPa(G))	Below 2.451MPa(G)	2.451MPa=Comp. design pressure (high)
4	Compression Ratio	Below 20		Comp. Ratio: High abs/Low abs
5	Winding Temp	Max.115°C	Max.130°C	
6	Shell Bottom Temp. (Refrigerant Temp.)	Max.: 90°C ----- Condensing. Temp.+5.5K Min. (running)		At the bottom of crankcase. Crankcase heater (Optional) 2~7.5HP: Install at rating conditions 10~20HP: Long operation at designated location
7	Discharge Gas Temp	130°C Max.	150°C Max.	Surface temp. of discharge pipe (Within 50mm of the discharge fitting)
8	Suction gas Temp	Evap.Temp.+10K Min.(sub-heat) ----- NO.5, NO.6, NO.7 must meet the requirements at the same time.		Surface temp. of suction pipe (Within 300mm of the suction fitting)
9	Running Voltage	Within rated voltage ± 10% ----- Within 2% of the rated voltage.		Voltage at compressor terminals
10	Starting Voltage	85% of the rated voltage Min.		Voltage at compressor terminals
11	On/Off cycling	For at least 10 minutes		
12	On/OFF Frequency	under 200,000 cycles		
13	Refrigerant charge	Do not charge refrigerant too much to cause damage of compressor (charge as less as possible)		
14	Level of Oil	Between high level and low level (running)		Oil-level meter
15	Tubing/Piping	<ul style="list-style-type: none"> · Use fully clean and dry tubing. · No resonating resonance allowed with piping design. · Use Nitrogen to carry on welding. · No oxide film oxide film in the inner side of pipe. · Make sure no leakage. · To ensure refrigerating oil return, use at least 3.8m/s horizontal suction pipe, or rse mim. 7.6m/s vertical pipe. 		
16	System Moisture Level	200ppm Max.		Moisture remained in the suction pipe (60°C)
17	System Uncondensable Gas Level	1 Vol.% Max. Residual Oxygen 0.1 Vol.% Max.		24 hrs. after vacuuming:1.01kPa Max.
18	Angle of inclination	2~7.5HP: 3° Max. 10~20HP: 5° Max.		Keep compressor in level position. Tilt within the range if necessary.

Other instructions:

- Must have Nitrogen flows while using a opened compressor.
- Do not lay aside over 15 min. while compressor is opened.
- Do not use the compressor to compress air.
- While vacuuming from both sides of high-pressure and low-pressure, refrigerant should be charged on the condenser discharge outlet.
- Do not energize the compressor under vacuumed condition.
- To test run for few seconds after refrigerant charging in order to protect the sliding parts.
- Do not use the compressor as a vacuum pump.
- Do not tilt over the compressor while carrying it.
- Use the compressor when ambient temp. is under 40C.
- Start to use the compressor within 12 months of the production date.
- To protect gasket and teflon seal please take off auxiliary valve from the compressor and weld while cooling.
- Suggest to install water/liquid seperator (at least collect 50% of refrigerant charge, install as closer to compressor as possible).
- Suggest to install ele.-magnet valve between expanding valve and accumulator.

(G): GAUGE PRESSURE

Semi-Hermetic Reciprocating Compressor For Refrigeration

Semi-hermetic compressor application standard & Limit (R404A)

The following instructions apply to semi-hermetic compressor:

- Apply to ordinary conditions.
- Apply to transitional short period of operation, such as start-up and defrost mode.

No	Item	Standard	Limit	Notes
1	Refrigerant	R404A (R125/R143a/R134a=44/52/4wt(%))		
2	Eevap. Temp.	-45 ~ -5°C (0.034 ~ 0.415MPa(G))		Compressor suction pressure
3	Cond. Temp.	+30 ~ +55°C (1.32 ~ 2.46MPa(G))	2.84MPa(G)	2.84MPa=Comp. design pressure (high)
4	Compression Ratio	20 Max.		Comp. Ratio: High abs/Low abs
5	Winding Temp	Max.115°C	Max.130°C	
6	Shell Bottom Temp. (Refrigerant Temp.)	Max.: 90°C ----- hit: Condensing pressure relative saturation temperature +5.5K (running)		At the bottom of crankcase. Crankcase heater (Optional) 2~7.5HP: Install at rating conditions 10~20HP: Long operation at designated location
7	Discharge Gas Temp	130°C Max.	150°C Max.	Surface temp. of discharge pipe (Within 50mm of the discharge fitting)
8	Suction gas Temp	Evap.Temp.+10K Min.(sub-heat) ----- NO.5, NO.6, NO.7 must meet the requirements at the same time.		Surface temp. of suction pipe (Within 300mm of the suction fitting)
9	Running Voltage	Within rated voltage ± 10% ----- Within 2% of the rated voltage.		Voltage at compressor terminals
10	Starting Voltage	85% of the rated voltage Min.		Voltage at compressor terminals
11	On/Off cycling	For at least 10 minutes		
12	On/OFF Frequency	under 200,000 cycles		
13	Refrigerant charge	Do not charge refrigerant too much to cause damage of compressor (charge as less as possible)		
14	Level of Oil	Between high level and low level (running)		Oil-level meter
15	Tubing/Piping	<ul style="list-style-type: none"> · Use fully clean and dry tubing. · No resonating resonance allowed with piping design. · Use Nitrogen to carry on welding. · No oxide film oxide film in the inner side of pipe. · Make sure no leakage. · To ensure refrigerating oil return, use at least 3.8m/s horizontal suction pipe, or rse mim. 7.6m/s vertical pipe. 		
16	System Moisture Level	200ppm Max.		Moisture remained in the suction pipe (60°C)
17	System Uncondensable Gas Level	1 Vol.% Max. Residual Oxygen 0.1 Vol.% Max.		24 hrs. after vacuuming:1.01kPa Max.
18	Angle of inclination	2~7.5HP: 3° Max. 10~20HP: 5° Max.		Keep compressor in level position. Tilt within the range if necessary.

Other instructions:

- Must have Nitrogen flows while using a opened compressor.
- Do not lay aside over 15 min. while compressor is opened.
- Do not use the compressor to compress air.
- While vacuuming from both sides of high-pressure and low-pressure, refrigerant should be charged on the condenser discharge outlet.
- Do not energize the compressor under vacuumed condition.
- To test run for few seconds after refrigerant charging in order to protect the sliding parts.
- Do not use the compressor as a vacuum pump.
- Do not tilt over the compressor while carrying it.
- Use the compressor when ambient temp. is under 40C.
- Start to use the compressor within 12 months of the production date.
- To protect gasket and teflon seal please take off auxiliary valve from the compressor and weld while cooling.
- Suggest to install water/liquid separator (at least collect 50% of refrigerant charge, install as closer to compressor as possible).
- Suggest to install ele.-magnet valve between expanding valve and accumulator.

(G): GAUGE PRESSURE

R404A

Semi-Hermetic Reciprocating Compressor For Refrigeration

Technical Specif.

Series			CL1		CL2		
Model			C-L15M8H	C-L22M8F	C-L28M8G	C-L37M8L	
Code			805 030 68	805 046 68	805 139 68	805 343 68	
Refrigerant			R22	R22	R22	R22	
Nominal Output		kW	1.5	2.2	2.8	3.7	
Evaporating Temp. Range		°C	-40~-5	-40~-5	-40~-5	-40~-5	
Cooling Method		-	FAN COOLING	FAN COOLING	FAN COOLING	FAN COOLING	
Rated Power Source	Phase	-	3	3	3	3	
	Frequency	Hz	50	50	50	50	
	Voltage	V	380-415	380-415	380-415	380-415	
Rated Specification	Capacity	kW	2.44	3.56	5.35	7.50	
	Rated Power	kW	1.20	1.75	2.52	3.40	
	Current	A	2.5	3.5	5.1	6.8	
Compressor	Dia. of Cylinder	ømm	40.0	48.0	55.0	55.0	
	Stroke	mm	29.0	29.0	33.0	44.0	
	No. of Cylinder	-	2	2	2	2	
	Cylinder Volume	cm ³ /rev		72.8	105.0	156.8	209.0
		m ³ /h		6.33	9.14	13.64	18.18
	Suction Line	mm	12.7	15.9	19.1	22.2	
	Discharge Line	mm	12.7	15.9	15.9	15.9	
	Oil Type	-	3GSD	3GSD	3GSD	3GSD	
Oil Charge	L	0.9	0.9	2.8	2.8		
Motor	Type	-	3-phase induction motor (3IR)	3-phase induction motor (3IR)	3-phase induction motor (3IR)	3-phase induction motor (3IR)	
	No. of Poles	-	4	4	4	4	
	Wiring	-	Y	△	Y	Y	
	Nominal Revolution	min ⁻¹	1,450	1,450	1,450	1,450	
	Locked Torque	N-m	30.0	43.5	60.4	75.4	
	Starting Torque	N-m	28.4	38.0	55.3	72.2	
	Start Current	A	22.0	27.0	42.5	52.5	
	Thermal Protector	°C	130	130	130	130	
	Thermal Protector Reset	°C	108	108	108	108	
Weight (Including oil)		kg	53.0	56.5	90.0	92.0	

Rating Conditions: Condensing Temp. 40.5°C / Evaporating Temp. -15°C / Suction Gas Temp. 18.3°C / Subcooling 0 K

Technical Specif.

Series			CL2		
Model			C-L45M8D	C-L55M8E	
Code			805 533 68	805 444 68	
Refrigerant			R22	R22	
Nominal Output		kW	4.5	5.5	
Evaporating Temp. Range		°C	-40~-5	-40~-5	
Cooling Method		-	FAN COOLING	FAN COOLING	
Rated Power Source	Phase	-	3	3	
	Frequency	Hz	50	50	
	Voltage	V	380-415	380-415	
Rated Specification	Capacity	kW	10.00	10.99	
	Rated Power	kW	4.65	4.94	
	Current	A	9.8	9.9	
Compressor	Dia. of Cylinder	ømm	62.0	62.0	
	Stroke	mm	44.0	48.4	
	No. of Cylinder	-	2	2	
	Cylinder Volume	cm ³ /rev		265.6	292.1
		m ³ /h		23.11	25.41
	Suction Line	mm	28.6	28.6	
	Discharge Line	mm	19.1	19.1	
	Oil Type	-	3GSD	3GSD	
Oil Charge	L	3.0	3.0		
Motor	Type	-	3-phase induction motor (3IR)	3-phase induction motor (3IR)	
	No. of Poles	-	4	4	
	Wiring	-	Y	△	
	Nominal Revolution	min ⁻¹	1,450	1,450	
	Locked Torque	N-m	120.0	125.2	
	Starting Torque	N-m	90.2	110.7	
	Start Current	A	73.5	86.0	
	Thermal Protector	°C	130	130	
Thermal Protector Reset	°C	108	108		
Weight (Including oil)		kg	95.0	100.0	

R22

Rating Conditions: Condensing Temp. 40.5°C / Evaporating Temp. -15°C / Suction Gas Temp. 18.3°C / Subcooling 0 K

R22
Technical Specif.

Series			CL3							
Model			C-L75M81		C-L90M82		C-L105M82		C-L150M82	
Code			805 731 68		805 742 68		805 840 68		805 934 68	
Refrigerant			R22		R22		R22		R22	
Nominal Output		kW	7.5		9.0		10.5		15.0	
Evaporating Temp. Range		°C	-40~-5		-40~-5		-40~-5		-40~-5	
Cooling Method		-	喷液冷却 Liquid Injection		喷液冷却 Liquid Injection		喷液冷却 Liquid Injection		喷液冷却 Liquid Injection	
Rated Power Source	Phase	-	3		3		3		3	
	Frequency	Hz	50	60	50	60	50	60	50	60
	Voltage	V	380-415	440	380-415	440	380-415	440	380-415	440
Rated Specification	Capacity	kW	15.70	18.75	17.40	20.90	20.30	25.10	30.30	36.50
	Rated Power	kW	6.80	8.40	8.30	9.90	9.70	12.20	13.80	17.30
	Current	A	12.5	13.1	15.6	15.9	19.6	20.3	26.2	27.7
Compressor	Dia. of Cylinder	ømm	62.0		62.0		62.0		62.0	
	Stroke	mm	37.6		43.3		50.0		70.0	
	No. of Cylinder	-	4		4		4		4	
	Cylinder Volume	cm ³ /rev	454.0		522.0		604.0		845.0	
		m ³ /h	39.50	47.67	45.41	54.81	52.55	63.42	73.52	88.73
	Suction Line	mm	28.6		28.6		34.9		41.5	
	Discharge Line	mm	22.2		22.2		22.2		28.6	
	Oil Type	-	3GSD		3GSD		3GSD		3GSD	
Oil Charge	L	5.2		5.2		5.2		5.2		
Motor	Type	-	3-phase induction motor (3IR)		3-phase induction motor (3IR)		3-phase induction motor (3IR)		3-phase induction motor (3IR)	
	No. of Poles	-	4		4		4		4	
	Wiring	-	△		△		△		△	
	Nominal Revolution	min ⁻¹	1,450	1,750	1,450	1,750	1,450	1,750	1,450	1,750
	Locked Torque	N·m	118.9		121.0		169.1		236.3	
	Starting Torque	N·m	104.4		110.0		155.8		198.0	
	Start Current	A	95.0		99.0		126.0		175.0	
	Thermal Protector	°C	130		130		130		130	
Thermal Protector Reset	°C	108		108		108		108		
Weight (Including oil)		kg	147.5		147.5		154.5		199.5	

Rating Conditions: Condensing Temp. 40.5°C / Evaporating Temp. -15°C / Suction Gas Temp. 18.3°C / Subcooling 0 K

Technical Specif.

Series			CL1	CL2		
Model			C-L22M9C	C-L37M9H	C-L55M9D	
Code			805 042 69	805 340 69	805 442 69	
Refrigerant			R22	R22	R22	
Nominal Output		kW	2.2	3.7	5.5	
Evaporating Temp. Range		°C	-40~-5	-40~-5	-40~-5	
Cooling Method		-	FAN COOLING	FAN COOLING	FAN COOLING	
Rated Rower Source	Phase	-	3	3	3	
	Frequency	Hz	60	60	60	
	Voltage	V	380	380	380	
Rated Specifi-cation	Capacity	kW	4.21	8.49	12.33	
	Rated Power	kW	2.12	4.00	5.84	
	Current	A	4.1	7.5	11.3	
Compressor	Dia. of Cylinder	ømm	48.0	55.0	62.0	
	Stroke	mm	29.0	44.0	48.4	
	No. of Cylinder	-	2	2	2	
	Cylinder Volume	cm ³ /rev		105.0	209.0	292.1
		m ³ /h		11.03	21.95	30.67
	Suction Line	mm	15.9	22.2	28.6	
	Discharge Line	mm	15.9	15.9	19.1	
	Oil Type	-	3GSD	3GSD	3GSD	
Oil Charge	L	0.9	2.8	3.0		
Motor	Type	-	3-phase induction motor (3IR)	3-phase induction motor (3IR)	3-phase induction motor (3IR)	
	No. of Poles	-	4	4	4	
	Wiring	-	Y	Y	Y	
	Nominal Revolution	min ⁻¹	1,750	1,750	1,750	
	Locked Torque	N-m	45.9	70.6	110.4	
	Starting Torque	N-m	40.0	64.7	103.0	
	Start Current	A	34.3	61.4	95.3	
	Thermal Protector	°C	130	130	130	
Thermal Protector Reset	°C	108	108	108		
Weight (Including oil)		kg	56.5	92.0	100.0	

R22

Rating Conditions: Condensing Temp. 40.5°C / Evaporating Temp. -15°C / Suction Gas Temp. 18.3°C / Subcooling 0 K

■ Technical Specif.

Series			CL3		
Model			C-L75M91	C-L113M91	C-L150M91
Code			805 731 69	805 831 69	805 931 69
Refrigerant			R22	R22	R22
Nominal Output		kW	7.5	11.25	15.0
Evaporating Temp. Range		°C	-40~-5	-40~-5	-40~-5
Cooling Method		-	Liquid Injection	Liquid Injection	Liquid Injection
Rated Power Source	Phase	-	3	3	3
	Frequency	Hz	60	60	60
	Voltage	V	380	380	380
Rated Specification	Capacity	kW	18.70	25.00	36.05
	Rated Power	kW	8.70	12.00	17.80
	Current	A	15.7	21.7	32.5
Compressor	Dia. of Cylinder	ømm	62.0	62.0	62.0
	Stroke	mm	37.6	50.0	70.0
	No. of Cylinder	-	4	4	4
	Cylinder Volume	cm ³ /rev	454.0	604.0	845.0
		m ³ /h	47.67	63.42	88.73
	Suction Line	mm	28.6	34.9	41.5
	Discharge Line	mm	22.2	22.2	28.6
	Oil Type	-	3GSD	3GSD	3GSD
Oil Charge	L	5.2	5.2	5.2	
Motor	Type	-	3-phase induction motor (3IR)	3-phase induction motor (3IR)	3-phase induction motor (3IR)
	No. of Poles	-	4	4	4
	Wiring	-	△	△	Y or △
	Nominal Revolution	min ⁻¹	1,750	1,750	1,750
	Locked Torque	N-m	116.4	147.9	237.3
	Starting Torque	N-m	98.9	134.8	215.7
	Start Current	A	105.0	136.0	198.0
	Thermal Protector	°C	130	130	130
Thermal Protector Reset	°C	108	108	108	
Weight (Including oil)		kg	147.5	154.5	199.5

Rating Conditions: Condensing Temp. 40.5°C / Evaporating Temp. -15°C / Suction Gas Temp. 18.3°C / Subcooling 0 K

Technical Specif.

Series			CL1				CL2			
Model			C-LN15M8A		C-LN22M8A		C-LN28M8A		C-LN37M8A	
Code			805 060 68		805 047 68		805 140 68		805 344 68	
Refrigerant			R404A		R404A		R404A		R404A	
Nominal Output		kW	1.5		2.2		2.8		3.7	
Evaporating Temp. Range		°C	-45~-5		-45~-5		-45~-5		-45~-5	
Cooling Method		-	FAN COOLING		FAN COOLING		FAN COOLING		FAN COOLING	
Rated Rower Source	Phase	-	3		3		3		3	
	Frequency	Hz	50	60	50	60	50	60	50	60
	Voltage	V	380-415	440	380-415	440	380-415	440	380-415	440
Rated Specifi-cation	Capacity	kW	2.45	2.86	3.57	4.08	4.97	5.78	7.64	8.58
	Rated Power	kW	1.38	1.56	1.93	2.24	2.79	3.47	3.71	4.25
	Current	A	2.8	2.9	3.8	3.9	5.5	5.7	7.4	7.6
Compressor	Dia. of Cylinder	ømm	40.0		48.0		55.0		55.0	
	Stroke	mm	29.0		29.0		33.0		44.0	
	No. of Cylinder	-	2		2		2		2	
	Cylinder Volume	cm³/rev	72.8		105.0		156.8		209.0	
		m³/h	6.33	7.64	9.14	11.03	13.64	16.46	18.18	21.95
	Suction Line	mm	12.7		15.9		19.1		22.2	
	Discharge Line	mm	12.7		15.9		15.9		15.9	
	Oil Type	-	FV32S		FV32S		FV32S		FV32S	
Oil Charge	L	0.9		0.9		2.8		2.8		
Motor	Type	-	3-phase induction motor (3IR)		3-phase induction motor (3IR)		3-phase induction motor (3IR)		3-phase induction motor (3IR)	
	No. of Poles	-	4		4		4		4	
	Wiring	-	Y		△		Y		Y	
	Nominal Revolution	min ⁻¹	1,450	1,750	1,450	1,750	1,450	1,750	1,450	1,750
	Locked Torque	N-m	30.0		43.5		60.4		75.4	
	Starting Torque	N-m	28.4		38.0		55.3		72.2	
	Start Current	A	22.0		27.0		42.5		52.5	
	Thermal Protector	°C	130		130		130		130	
Thermal Protector Reset	°C	108		108		108		108		
Weight (Including oil)		kg	53.0		56.5		90.0		92.0	

R404A

Rating Conditions: Condensing Temp. 40.5°C / Evaporating Temp. -15°C / Suction Gas Temp. 18.3°C / Subcooling 0 K

Semi-Hermetic Reciprocating Compressor For Refrigeration

Technical Specif.

Series			CL2			
Model			C-LN45M8A		C-LN55M8A	
Code			805 535 68		805 445 68	
Refrigerant			R404A		R404A	
Nominal Output		kW	4.5		5.5	
Evaporating Temp. Range		°C	-45~-5		-45~-5	
Cooling Method		-	FAN COOLING		FAN COOLING	
Rated Power Source	Phase	-	3		3	
	Frequency	Hz	50	60	50	60
	Voltage	V	380-415	440	380-415	440
Rated Specification	Capacity	kW	9.03	9.93	9.99	11.33
	Rated Power	kW	4.97	6.15	5.47	6.57
	Current	A	9.9	10.3	10.7	11.0
Compressor	Dia. of Cylinder	ømm	62.0		62.0	
	Stroke	mm	44.0		48.4	
	No. of Cylinder	-	2		2	
	Cylinder Volume	cm ³ /rev	265.6		292.1	
		m ³ /h	23.11	27.89	25.41	30.67
	Suction Line	mm	28.6		28.6	
	Discharge Line	mm	19.1		19.1	
	Oil Type	-	FV32S		FV32S	
Oil Charge	L	3.0		3.0		
Motor	Type	-	3-phase induction motor (3IR)		3-phase induction motor (3IR)	
	No. of Poles	-	4		4	
	Wiring	-	Y		△	
	Nominal Revolution	min ⁻¹	1,450	1,750	1,450	1,750
	Locked Torque	N-m	120.0		125.2	
	Starting Torque	N-m	90.2		110.7	
	Start Current	A	73.5		86.0	
	Thermal Protector	°C	130		130	
Thermal Protector Reset	°C	108		108		
Weight (Including oil)		kg	95.0		100.0	

Rating Conditions: Condensing Temp. 40.5°C / Evaporating Temp. -15°C / Suction Gas Temp. 18.3°C / Subcooling 0 K

■ Technical Specif.

Series			CL3							
Model			C-LN75M81		C-LN90M81		C-LN105M81		C-LN150M81	
Code			805 737 68		805 741 68		805 838 68		805 933 68	
Refrigerant			R404A		R404A		R404A		R404A	
Nominal Output		kW	7.5		9.0		10.5		15.0	
Evaporating Temp. Range		°C	-45~-5		-45~-5		-45~-5		-45~-5	
Cooling Method		-	Liquid Injection		Liquid Injection		Liquid Injection		Liquid Injection	
Rated Power Source	Phase	-	3		3		3		3	
	Frequency	Hz	50	60	50	60	50	60	50	60
	Voltage	V	380-415	440	380-415	440	380-415	440	380-415	440
Rated Specification	Capacity	kW			18.67	21.20	22.80	25.80	32.35	36.20
	Rated Power	kW			9.27	11.47	11.15	13.57	16.21	19.71
	Current	A			17.4	18.5	22.2	23.1	30.7	31.6
Compressor	Dia. of Cylinder	ømm	62.0		62.0		62.0		62.0	
	Stroke	mm	37.6		43.3		50.0		70.0	
	No. of Cylinder	-	4		4		4		4	
	Cylinder Volume	cm ³ /rev	454.0		522.0		604.0		845.0	
		m ³ /h	39.50	47.67	45.41	54.81	52.55	63.42	73.52	88.73
	Suction Line	mm	28.6		28.6		34.9		41.5	
	Discharge Line	mm	22.2		22.2		22.2		28.6	
	Oil Type	-	FV32S		FV32S		FV32S		FV32S	
Oil Charge	L	5.2		5.2		5.2		5.2		
Motor	Type	-	3-phase induction motor (3IR)		3-phase induction motor (3IR)		3-phase induction motor (3IR)		3-phase induction motor (3IR)	
	No. of Poles	-	4		4		4		4	
	Wiring	-	△		△		△		Y 或 or △	
	Nominal Revolution	min ⁻¹	1,450	1,750	1,450	1,750	1,450	1,750	1,450	1,750
	Locked Torque	N-m	130.0		130.0				243.7	
	Starting Torque	N-m	117.3		117.3				202.0	
	Start Current	A	104.5		104.5				178.0	
	Thermal Protector	°C	130		130		130		130	
Thermal Protector Reset	°C	108		108		108		108		
Weight (Including oil)		kg	147.5		147.5		154.5		199.5	

R404A

Rating Conditions: Condensing Temp. 40.5°C / Evaporating Temp. -15°C / Suction Gas Temp. 18.3°C / Subcooling 0 K

Technical Specif.

Series		CL3			
Model		C-LN75M91	C-LN113M91	C-LN150M91	
Code		805 737 69	805 838 69	805 933 69	
Refrigerant		R404A	R404A	R404A	
Nominal Output	kW	7.5	11.25	15.0	
Evaporating Temp. Range	°C	-45~-5	-45~-5	-45~-5	
Cooling Method	-	Liquid Injection	Liquid Injection	Liquid Injection	
Rated Power Source	Phase	-	3	3	3
	Frequency	Hz	60	60	60
	Voltage	V	380	380	380
Rated Specification	Capacity	kW	19.40	27.20	40.20
	Rated Power	kW	9.75	13.70	20.10
	Current	A	17.3	24.7	35.8
Compressor	Dia. of Cylinder	ømm	62.0	62.0	62.0
	Stroke	mm	37.6	50.0	70.0
	No. of Cylinder	-	4	4	4
	Cylinder Volume	cm ³ /rev	454.0	604.0	845.0
		m ³ /h	47.67	63.42	88.73
	Suction Line	mm	28.6	34.9	41.5
	Discharge Line	mm	22.2	22.2	28.6
	Oil Type	-	FV32S	FV32S	FV32S
Oil Charge	L	5.2	5.2	5.2	
Motor	Type	-	3-phase induction motor (3IR)	3-phase induction motor (3IR)	3-phase induction motor (3IR)
	No. of Poles	-	4	4	4
	Wiring	-	△	△	Y or △
	Nominal Revolution	min ⁻¹	1,750	1,750	1,750
	Locked Torque	N-m	116.4	147.9	239.7
	Starting Torque	N-m	98.9	134.8	211.8
	Start Current	A	105.0	136.0	194.0
	Thermal Protector	°C	130	130	130
Thermal Protector Reset	°C	108	108	108	
Weight (Including oil)	kg	147.5	154.5	199.5	

Rating Conditions: Condensing Temp. 40.5°C / Evaporating Temp. -15°C / Suction Gas Temp. 18.3°C / Subcooling 0 K

Technical Specif.

Series			CL1				CL2			
Model			C-LN15M3A		C-LN22M3A		C-LN28M3A		C-LN37M3A	
Code			805 060 63		805 047 63		805 140 63		805 344 63	
Refrigerant			R404A		R404A		R404A		R404A	
Nominal Output		kW	1.5		2.2		2.8		3.7	
Evaporating Temp. Range		°C	-45~-5		-45~-5		-45~-5		-45~-5	
Cooling Method		-	FAN COOLING		FAN COOLING		FAN COOLING		FAN COOLING	
Rated Power Source	Phase	-	3		3		3		3	
	Frequency	Hz	50	60	50	60	50	60	50	60
	Voltage	V	200	200-220	200	200-220	200	200-220	200	200-220
Rated Specification	Capacity	kW	2.65	3.05	3.80	4.41	5.75	6.75	7.50	8.80
	Rated Power	kW	1.42	1.68	2.01	2.39	2.85	3.40	4.05	4.95
	Current	A	5.5	5.75	7.8	8.1	10.8	11.5	15.7	16.8
Compressor	Dia. of Cylinder	ømm	40.0		48.0		55.0		55.0	
	Stroke	mm	29.0		29.0		33.0		44.0	
	No. of Cylinder	-	2		2		2		2	
	Cylinder Volume	cm ³ /rev	72.8		105.0		156.8		209.0	
		m ³ /h	6.33	7.64	9.14	11.03	13.64	16.46	18.18	21.95
	Suction Line	mm	12.7		15.9		19.1		22.2	
	Discharge Line	mm	12.7		15.9		15.9		15.9	
	Oil Type	-	FV32S		FV32S		FV32S		FV32S	
Oil Charge	L	0.9		0.9		2.8		2.8		
Motor	Type	-	3-phase induction motor (3IR)		3-phase induction motor (3IR)		3-phase induction motor (3IR)		3-phase induction motor (3IR)	
	No. of Poles	-	4		4		4		4	
	Wiring	-	Y		Y		2Y		2Y	
	Nominal Revolution	min ⁻¹	1,450	1,750	1,450	1,750	1,450	1,750	1,450	1,750
	Locked Torque	N-m	45.2		45.2		66.0		82.2	
	Starting Torque	N-m	42.3		42.3		59.1		74.6	
	Start Current	A	58.0		58.0		88.0		112.0	
	Thermal Protector	°C	130		130		130		130	
Thermal Protector Reset	°C	108		108		108		108		
Weight (Including oil)		kg	53.0		56.5		90.0		92.0	

R404A

Rating Conditions: Condensing Temp. 40.5°C / Evaporating Temp. -15°C / Suction Gas Temp. 18.3°C / Subcooling 0 K

Semi-Hermetic Reciprocating Compressor For Refrigeration

Technical Specif.

Series			CL2			
Model			C-LN45M3A		C-LN55M3A	
Code			805 535 63		805 445 63	
Refrigerant			R404A		R404A	
Nominal Output		kW	4.5		5.5	
Evaporating Temp. Range		°C	-45~-5		-45~-5	
Cooling Method		-	FAN COOLING		FAN COOLING	
Rated Power Source	Phase	-	3		3	
	Frequency	Hz	50	60	50	60
	Voltage	V	200	200-220	200	200-220
Rated Specification	Capacity	kW	10.40	12.00	11.30	13.20
	Rated Power	kW	5.05	6.00	5.55	6.57
	Current	A	20.2	20.3	21.3	21.6
Compressor	Dia. of Cylinder	ømm	62.0		62.0	
	Stroke	mm	44.0		48.4	
	No. of Cylinder	-	2		2	
	Cylinder Volume	cm ³ /rev	265.6		292.1	
		m ³ /h	23.11	27.89	25.41	30.67
	Suction Line	mm	28.6		28.6	
	Discharge Line	mm	19.1		19.1	
	Oil Type	-	FV32S		FV32S	
Oil Charge	L	3.0		3.0		
Motor	Type	-	3-phase induction motor (3IR)		3-phase induction motor (3IR)	
	No. of Poles	-	4		4	
	Wiring	-	2Y		△	
	Nominal Revolution	min ⁻¹	1,450	1,750	1,450	1,750
	Locked Torque	N-m	108.7		120.1	
	Starting Torque	N-m	97.2		118.3	
	Start Current	A	147.0		170.0	
	Thermal Protector	°C	130		130	
Thermal Protector Reset	°C	108		108		
Weight (Including oil)		kg	95.0		100.0	

Rating Conditions: Condensing Temp. 40.5°C / Evaporating Temp. -15°C / Suction Gas Temp. 18.3°C / Subcooling 0 K

Technical Specif.

Series			CL3							
Model			C-LN75M31		C-LN90M31		C-LN105M31		C-LN150M31	
Code			805 737 63		805 741 63		805 838 63		805 933 63	
Refrigerant			R404A		R404A		R404A		R404A	
Nominal Output		kW	7.5		9.0		10.5		15.0	
Evaporating Temp. Range		°C	-45~-5		-45~-5		-45~-5		-45~-5	
Cooling Method		-	Liquid Injection		Liquid Injection		Liquid Injection		Liquid Injection	
Rated Power Source	Phase	-	3		3		3		3	
	Frequency	Hz	50	60	50	60	50	60	50	60
	Voltage	V	200	200-220	200	200-220	200	200-220	200	200-220
Rated Specification	Capacity	kW	16.60	19.70	19.20	22.70	22.70	26.60	33.80	39.20
	Rated Power	kW	7.90	9.64	9.40	11.50	11.40	13.80	16.20	19.70
	Current	A	30.4	31.9	35.5	37.8	44.9	45.7	61.3	64.8
Compressor	Dia. of Cylinder	ømm	62.0		62.0		62.0		62.0	
	Stroke	mm	37.6		43.3		50.0		70.0	
	No. of Cylinder	-	4		4		4		4	
	Cylinder Volume	cm ³ /rev	454.0		522.0		604.0		845.0	
		m ³ /h	39.50	47.67	45.41	54.81	52.55	63.42	73.52	88.73
	Suction Line	mm	28.6		28.6		34.9		41.5	
	Discharge Line	mm	22.2		22.2		22.2		28.6	
	Oil Type	-	FV32S		FV32S		FV32S		FV32S	
Oil Charge	L	5.2		5.2		5.2		5.2		
Motor	Type	-	3-phase induction motor (3IR)		3-phase induction motor (3IR)		3-phase induction motor (3IR)		3-phase induction motor (3IR)	
	No. of Poles	-	4		4		4		4	
	Wiring	-	2△		2△		2△		2△	
	Nominal Revolution	min ⁻¹	1,450	1,750	1,450	1,750	1,450	1,750	1,450	1,750
	Locked Torque	N-m	112.8		119.6		151.0		221.2	
	Starting Torque	N-m	89.4		101.0		125.5		178.5	
	Start Current	A	202.0		220.0		280.0		341.0	
	Thermal Protector	°C	130		130		130		130	
	Thermal Protector Reset	°C	108		108		108		108	
Weight (Including oil)		kg	147.5		147.5		154.5		199.5	

R404A

Rating Conditions: Condensing Temp. 40.5°C / Evaporating Temp. -15°C / Suction Gas Temp. 18.3°C / Subcooling 0 K

Semi-Hermetic Reciprocating Compressor For Refrigeration

Performance Data

Power: 50Hz 380V
Subcooling: 0 K

Suction Gas Temp.: 18.3°C
Cooling Method: Fan Cooling

Compressor	Item	Condensing Temp.	Evaporating Temp.								
			-40	-35	-30	-25	-20	-15	-10	-5	
C-L15M8H 805 030 68 1.5kW	Capacity Q (kW)	30	0.51	0.77	1.11	1.55	2.08	2.69	3.40	4.20	
		35	0.44	0.69	1.03	1.46	1.97	2.57	3.26	4.03	
		40.5	0.36	0.61	0.95	1.36	1.86	2.44	3.10	3.85	
		45	0.31	0.56	0.88	1.29	1.77	2.34	2.98	3.71	
		50	0.26	0.50	0.82	1.21	1.68	2.23	2.85	3.55	
	Input P (kW)	30	0.47	0.62	0.75	0.88	0.99	1.09	1.17	1.25	
		35	0.50	0.65	0.80	0.93	1.04	1.14	1.22	1.29	
		40.5	0.53	0.70	0.85	0.99	1.10	1.20	1.28	1.34	
		45	0.55	0.73	0.90	1.04	1.16	1.25	1.33	1.38	
		50	0.58	0.78	0.95	1.10	1.22	1.31	1.38	1.43	
	Current A (kW)	30	1.70	1.84	1.98	2.12	2.26	2.40	2.55	2.69	
		35	1.75	1.89	2.03	2.16	2.31	2.45	2.59	2.74	
		40.5	1.81	1.95	2.08	2.22	2.36	2.50	2.64	2.79	
		45	1.86	1.99	2.13	2.26	2.40	2.54	2.69	2.83	
		50	1.92	2.05	2.18	2.32	2.45	2.59	2.73	2.88	
	C-L22M8F 805 046 68 2.2kW	Capacity Q (kW)	30	0.75	1.12	1.62	2.26	3.03	3.93	4.96	6.13
			35	0.64	1.01	1.50	2.12	2.87	3.75	4.75	5.88
			40.5	0.53	0.89	1.38	1.99	2.71	3.56	4.53	5.62
			45	0.45	0.81	1.29	1.88	2.59	3.41	4.35	5.41
			50	0.38	0.73	1.19	1.77	2.45	3.25	4.16	5.19
Input P (kW)		30	0.69	0.90	1.10	1.28	1.44	1.59	1.71	1.82	
		35	0.72	0.95	1.16	1.35	1.52	1.66	1.78	1.89	
		40.5	0.77	1.02	1.24	1.44	1.61	1.75	1.87	1.96	
		45	0.80	1.07	1.31	1.51	1.68	1.83	1.94	2.02	
		50	0.84	1.13	1.38	1.60	1.78	1.92	2.02	2.09	
Current A (kW)		30	2.38	2.57	2.77	2.96	3.16	3.36	3.57	3.77	
		35	2.45	2.64	2.84	3.03	3.23	3.43	3.63	3.83	
		40.5	2.54	2.72	2.91	3.11	3.30	3.50	3.70	3.90	
		45	2.60	2.79	2.98	3.17	3.36	3.56	3.76	3.96	
		50	2.68	2.87	3.05	3.24	3.43	3.63	3.83	4.03	
C-L28M8G 805 139 68 2.8kW		Capacity Q (kW)	30	1.13	1.68	2.44	3.39	4.55	5.90	7.46	9.21
			35	0.96	1.51	2.26	3.19	4.32	5.64	7.14	8.84
			40.5	0.80	1.34	2.07	2.98	4.08	5.35	6.81	8.44
			45	0.68	1.22	1.93	2.82	3.89	5.13	6.54	8.13
			50	0.58	1.10	1.79	2.65	3.68	4.88	6.25	7.79
	Input P (kW)	30	0.99	1.30	1.58	1.84	2.07	2.28	2.47	2.63	
		35	1.04	1.37	1.68	1.95	2.18	2.39	2.57	2.71	
		40.5	1.10	1.46	1.79	2.07	2.31	2.52	2.69	2.82	
		45	1.15	1.54	1.88	2.18	2.43	2.63	2.79	2.90	
		50	1.21	1.63	1.99	2.30	2.56	2.76	2.91	3.00	
	Current A (kW)	30	3.47	3.75	4.03	4.32	4.61	4.90	5.20	5.49	
		35	3.58	3.85	4.13	4.42	4.70	4.99	5.29	5.59	
		40.5	3.70	3.97	4.25	4.53	4.81	5.10	5.39	5.69	
		45	3.80	4.07	4.34	4.62	4.90	5.19	5.48	5.77	
		50	3.91	4.18	4.45	4.72	5.00	5.29	5.58	5.87	
	C-L37M8L 805 343 68 3.7kW	Capacity Q (kW)	30	1.58	2.36	3.42	4.76	6.38	8.28	10.46	12.91
			35	1.34	2.12	3.16	4.48	6.05	7.90	10.01	12.39
			40.5	1.12	1.88	2.91	4.18	5.71	7.50	9.54	11.84
			45	0.96	1.71	2.71	3.96	5.45	7.18	9.17	11.40
			50	0.81	1.54	2.51	3.72	5.16	6.85	8.77	10.93
Input P (kW)		30	1.34	1.75	2.13	2.48	2.80	3.08	3.33	3.54	
		35	1.41	1.85	2.26	2.63	2.95	3.23	3.47	3.66	
		40.5	1.49	1.97	2.41	2.79	3.12	3.40	3.63	3.80	
		45	1.56	2.08	2.54	2.94	3.27	3.55	3.76	3.92	
		50	1.64	2.20	2.69	3.10	3.45	3.72	3.92	4.05	
Current A (kW)		30	4.63	5.00	5.38	5.76	6.14	6.53	6.93	7.33	
		35	4.77	5.14	5.51	5.89	6.27	6.66	7.05	7.45	
		40.5	4.93	5.29	5.66	6.04	6.42	6.80	7.19	7.58	
		45	5.06	5.42	5.79	6.16	6.54	6.92	7.31	7.70	
		50	5.21	5.57	5.93	6.30	6.67	7.05	7.44	7.83	

R22

Performance Data

Power: 50Hz 380V
Subcooling: 0 K

Suction Gas Temp.: 18.3°C
Cooling Method: Fan Cooling

Compressor	Item	Condensing Temp.	Evaporating Temp.							
			-40	-35	-30	-25	-20	-15	-10	-5
C-L45M8D 805 533 68 4.5kW	Capacity Q (kW)	30	1.90	3.50	5.18	6.93	8.76	10.67	12.65	14.71
		35	1.70	3.37	5.07	6.79	8.55	10.34	12.17	14.02
		40.5	1.50	3.23	4.95	6.65	8.33	10.00	11.65	13.29
		45	1.35	3.13	4.85	6.53	8.15	9.73	11.25	12.72
		50	1.21	3.03	4.75	6.40	7.96	9.43	10.82	12.12
	Input P (kW)	30	1.78	2.46	3.06	3.57	3.99	4.33	4.58	4.75
		35	1.88	2.59	3.20	3.72	4.15	4.48	4.71	4.85
		40.5	1.99	2.73	3.38	3.91	4.33	4.65	4.86	4.96
		45	2.08	2.86	3.52	4.06	4.49	4.80	4.99	5.06
		50	2.19	3.01	3.69	4.24	4.67	4.96	5.13	5.17
	Current A (kW)	30	7.02	7.42	7.86	8.34	8.86	9.42	10.03	10.67
		35	7.17	7.57	8.00	8.49	9.02	9.60	10.22	10.90
		40.5	7.35	7.73	8.17	8.66	9.20	9.80	10.45	11.15
		45	7.49	7.87	8.31	8.81	9.36	9.97	10.63	11.36
		50	7.66	8.03	8.47	8.97	9.53	10.16	10.84	11.59
C-L55M8E 805 444 68 5.5kW	Capacity Q (kW)	30	2.32	3.86	5.60	7.54	9.66	11.98	14.49	17.20
		35	2.10	3.65	5.37	7.24	9.29	11.50	13.88	16.42
		40.5	1.88	3.43	5.11	6.94	8.89	10.99	13.22	15.59
		45	1.72	3.26	4.92	6.69	8.58	10.59	12.71	14.95
		50	1.56	3.09	4.71	6.43	8.25	10.16	12.16	14.26
	Input P (kW)	30	2.10	2.77	3.35	3.86	4.28	4.62	4.89	5.07
		35	2.20	2.87	3.46	3.97	4.41	4.77	5.06	5.27
		40.5	2.32	2.99	3.58	4.10	4.55	4.94	5.26	5.50
		45	2.43	3.09	3.68	4.21	4.68	5.08	5.42	5.70
		50	2.55	3.20	3.80	4.33	4.82	5.24	5.61	5.93
	Current A (kW)	30	7.66	7.90	8.20	8.54	8.93	9.38	9.87	10.42
		35	7.81	8.07	8.38	8.74	9.16	9.62	10.14	10.71
		40.5	7.99	8.26	8.59	8.97	9.41	9.90	10.45	11.05
		45	8.13	8.42	8.76	9.16	9.62	10.13	10.70	11.33
		50	8.29	8.59	8.96	9.38	9.86	10.40	11.00	11.66

R22

Performance Data

Power: 50Hz 380V
Subcooling: 0 K

Suction Gas Temp.: 18.3°C
Cooling Method: Liquid Injection

Compressor	Item	Condensing Temp.	Evaporating Temp.							
			-40	-35	-30	-25	-20	-15	-10	-5
C-L75M81 805 731 68 7.5kW	Capacity Q (kW)	30	3.46	5.43	7.91	10.91	14.43	18.46	23.01	28.07
		35	2.87	4.75	7.11	9.96	13.29	17.10	21.40	26.18
		40.5	2.31	4.09	6.31	8.99	12.12	15.70	19.74	24.22
		45	1.93	3.61	5.72	8.26	11.23	14.63	18.46	22.72
		50	1.57	3.15	5.12	7.51	10.31	13.51	17.13	21.15
	Input P (kW)	30	3.57	4.21	4.78	5.29	5.74	6.13	6.45	6.72
		35	3.64	4.31	4.92	5.48	5.98	6.44	6.84	7.18
		40.5	3.72	4.42	5.08	5.69	6.27	6.80	7.29	7.74
		45	3.79	4.51	5.21	5.87	6.51	7.12	7.69	8.24
		50	3.86	4.61	5.35	6.08	6.79	7.48	8.17	8.84
	Current A (kW)	30	8.66	9.36	10.00	10.59	11.12	11.59	12.00	12.36
		35	8.73	9.47	10.17	10.83	11.44	12.01	12.54	13.03
		40.5	8.82	9.60	10.36	11.09	11.81	12.50	13.17	13.82
		45	8.88	9.70	10.51	11.31	12.12	12.92	13.71	14.50
		50	8.96	9.80	10.67	11.56	12.47	13.40	14.35	15.31
	C-L90M82 805 742 68 9kW	Capacity Q (kW)	30	3.84	6.02	8.77	12.09	15.99	20.46	25.50
35			3.18	5.26	7.88	11.03	14.72	18.95	23.71	29.01
40.5			2.56	4.53	6.99	9.96	13.43	17.40	21.87	26.85
45			2.14	4.00	6.34	9.15	12.44	16.21	20.46	25.18
50			1.75	3.49	5.68	8.33	11.43	14.98	18.98	23.44
Input P (kW)		30	4.36	5.13	5.83	6.46	7.01	7.48	7.88	8.20
		35	4.45	5.26	6.01	6.69	7.30	7.86	8.34	8.76
		40.5	4.54	5.40	6.20	6.95	7.65	8.30	8.90	9.45
		45	4.62	5.51	6.35	7.17	7.94	8.68	9.39	10.06
		50	4.71	5.63	6.53	7.42	8.28	9.13	9.97	10.79
Current A (kW)		30	10.81	11.68	12.48	13.22	13.88	14.46	14.98	15.42
		35	10.90	11.82	12.70	13.51	14.28	14.99	15.65	16.26
		40.5	11.00	11.98	12.93	13.85	14.74	15.60	16.43	17.24
		45	11.09	12.10	13.11	14.12	15.12	16.12	17.11	18.10
		50	11.18	12.24	13.32	14.43	15.56	16.72	17.90	19.11
C-L105M82 805 840 68 10.5kW		Capacity Q (kW)	30	5.92	8.14	11.07	14.70	19.03	24.07	29.82
	35		4.84	6.99	9.79	13.27	17.41	22.21	27.68	33.82
	40.5		3.82	5.86	8.53	11.83	15.75	20.30	25.48	31.29
	45		3.12	5.06	7.61	10.75	14.50	18.84	23.79	29.34
	50		2.47	4.29	6.69	9.67	13.21	17.34	22.03	27.31
	Input P (kW)	30	4.94	5.91	6.78	7.56	8.25	8.84	9.34	9.74
		35	5.02	6.02	6.95	7.79	8.55	9.24	9.84	10.37
		40.5	5.12	6.15	7.12	8.04	8.90	9.70	10.44	11.13
		45	5.20	6.25	7.27	8.25	9.19	10.10	10.97	11.81
		50	5.28	6.36	7.43	8.48	9.53	10.57	11.59	12.61
	Current A (kW)	30	14.08	15.10	16.04	16.91	17.70	18.42	19.06	19.63
		35	14.16	15.22	16.24	17.20	18.11	18.97	19.78	20.55
		40.5	14.26	15.36	16.44	17.51	18.56	19.60	20.62	21.62
		45	14.33	15.46	16.61	17.77	18.94	20.13	21.34	22.55
		50	14.41	15.57	16.79	18.06	19.38	20.75	22.17	23.64
	C-L150M82 805 943 68 15kW	Capacity Q (kW)	30	8.09	13.32	18.70	24.24	29.94	35.79	41.80
35			7.01	11.41	16.21	21.42	27.04	33.06	39.49	46.32
40.5			5.96	9.51	13.72	18.59	24.11	30.30	37.14	44.65
45			5.20	8.11	11.87	16.47	21.92	28.22	35.37	43.37
50			4.46	6.72	10.01	14.34	19.71	26.11	33.56	42.04
Input P (kW)		30	7.19	8.31	9.40	10.45	11.47	12.46	13.41	14.33
		35	7.29	8.50	9.69	10.85	11.98	13.08	14.14	15.18
		40.5	7.40	8.73	10.03	11.31	12.57	13.80	15.01	16.19
		45	7.49	8.91	10.32	11.71	13.07	14.42	15.75	17.07
		50	7.59	9.12	10.65	12.16	13.66	15.15	16.63	18.10
Current A (kW)		30	18.40	19.53	20.70	21.90	23.14	24.42	25.73	27.08
		35	18.48	19.76	21.07	22.42	23.82	25.25	26.73	28.24
		40.5	18.58	20.01	21.49	23.01	24.58	26.20	27.87	29.58
		45	18.66	20.22	21.83	23.50	25.23	27.00	28.84	30.72
		50	18.75	20.45	22.23	24.06	25.96	27.93	29.96	32.05

R22

Performance Data

Power: 60Hz 380V
Subcooling: 0 K

Suction Gas Temp.: 18.3°C
Cooling Method: Fan Cooling

Compressor	Item	Condensing Temp.	Evaporating Temp.							
			-40	-35	-30	-25	-20	-15	-10	-5
C-L22M9C 805 042 69 2.2kW	Capacity Q (kW)	30	1.28	1.59	2.10	2.81	3.71	4.82	6.12	7.61
		35	1.22	1.50	1.97	2.63	3.48	4.52	5.75	7.16
		40.5	1.16	1.41	1.84	2.45	3.24	4.21	5.36	6.70
		45	1.12	1.34	1.73	2.31	3.05	3.97	5.07	6.34
		50	1.07	1.26	1.63	2.16	2.86	3.72	4.76	5.96
	Input P (kW)	30	1.10	1.25	1.41	1.58	1.75	1.92	2.09	2.27
		35	1.17	1.33	1.49	1.65	1.83	2.01	2.20	2.40
		40.5	1.26	1.41	1.57	1.74	1.92	2.12	2.33	2.55
		45	1.34	1.49	1.64	1.82	2.01	2.21	2.44	2.68
		50	1.44	1.57	1.73	1.90	2.10	2.32	2.57	2.83
	Current A (kW)	30	3.08	3.22	3.37	3.53	3.69	3.87	4.05	4.25
		35	3.20	3.32	3.46	3.61	3.79	3.98	4.19	4.42
		40.5	3.34	3.43	3.55	3.71	3.89	4.10	4.34	4.61
		45	3.46	3.53	3.64	3.79	3.97	4.20	4.47	4.78
		50	3.59	3.63	3.73	3.87	4.07	4.32	4.62	4.98
C-L37M9H 805 340 69 3.7kW	Capacity Q (kW)	30	2.11	2.81	3.87	5.28	7.07	9.21	11.71	14.58
		35	1.94	2.61	3.63	5.02	6.76	8.86	11.32	14.14
		40.5	1.77	2.40	3.39	4.73	6.43	8.49	10.90	13.67
		45	1.64	2.24	3.20	4.51	6.18	8.20	10.57	13.30
		50	1.50	2.08	3.00	4.28	5.91	7.89	10.22	12.90
	Input P (kW)	30	1.54	2.08	2.58	3.04	3.47	3.86	4.21	4.53
		35	1.64	2.13	2.61	3.07	3.51	3.93	4.32	4.70
		40.5	1.76	2.21	2.66	3.10	3.55	4.00	4.45	4.89
		45	1.87	2.27	2.69	3.13	3.59	4.06	4.55	5.06
		50	2.01	2.36	2.74	3.16	3.62	4.12	4.67	5.25
	Current A (kW)	30	4.64	5.14	5.64	6.15	6.66	7.19	7.71	8.24
		35	4.86	5.31	5.78	6.28	6.79	7.33	7.90	8.48
		40.5	5.11	5.51	5.94	6.42	6.94	7.50	8.10	8.75
		45	5.34	5.68	6.08	6.54	7.06	7.64	8.28	8.98
		50	5.60	5.88	6.23	6.67	7.19	7.79	8.48	9.24
C-L55M9D 805 442 69 5.5kW	Capacity Q (kW)	30	3.07	4.08	5.61	7.67	10.26	13.37	17.01	21.17
		35	2.82	3.79	5.28	7.28	9.81	12.87	16.44	20.54
		40.5	2.57	3.49	4.92	6.87	9.34	12.33	15.83	19.86
		45	2.38	3.26	4.65	6.55	8.97	11.91	15.36	19.32
		50	2.18	3.02	4.36	6.22	8.58	11.46	14.84	18.74
	Input P (kW)	30	2.25	3.03	3.76	4.44	5.06	5.63	6.15	6.62
		35	2.39	3.12	3.81	4.48	5.12	5.73	6.31	6.86
		40.5	2.57	3.22	3.88	4.53	5.19	5.84	6.49	7.14
		45	2.73	3.32	3.93	4.57	5.24	5.93	6.64	7.38
		50	2.94	3.44	4.00	4.62	5.29	6.02	6.81	7.66
	Current A (kW)	30	6.99	7.74	8.50	9.26	10.04	10.83	11.62	12.42
		35	7.32	8.00	8.71	9.46	10.24	11.05	11.90	12.78
		40.5	7.71	8.30	8.95	9.67	10.45	11.30	12.21	13.19
		45	8.05	8.56	9.16	9.85	10.63	11.51	12.47	13.53
		50	8.44	8.86	9.39	10.05	10.84	11.74	12.77	13.92

R22

Performance Data

Power: 60Hz 380V

Suction Gas Temp.: 18.3°C

Subcooling: 0 K

Cooling Method: Liquid Injection

Compressor	Item	Condensing Temp.	Evaporating Temp.							
			-40	-35	-30	-25	-20	-15	-10	-5
C-L75M91 805 731 69 7.5kW	Capacity Q (kW)	30	5.15	7.28	10.07	13.51	17.62	22.38	27.79	33.87
		35	4.19	6.20	8.84	12.11	16.02	20.56	25.73	31.53
		40.5	3.27	5.14	7.62	10.71	14.40	18.70	23.61	29.13
		45	2.64	4.39	6.73	9.66	13.18	17.29	21.99	27.28
		50	2.06	3.68	5.86	8.62	11.94	15.84	20.31	25.36
	Input P (kW)	30	4.67	5.47	6.19	6.84	7.41	7.90	8.32	8.67
		35	4.64	5.51	6.30	7.02	7.68	8.27	8.79	9.25
		40.5	4.62	5.55	6.42	7.23	7.99	8.70	9.35	9.94
		45	4.60	5.58	6.51	7.41	8.26	9.07	9.84	10.56
		50	4.57	5.61	6.62	7.61	8.57	9.50	10.41	11.29
	Current A (kW)	30	10.33	11.35	12.29	13.14	13.90	14.57	15.15	15.64
		35	10.43	11.49	12.49	13.42	14.29	15.09	15.83	16.51
		40.5	10.54	11.64	12.70	13.73	14.73	15.70	16.64	17.54
		45	10.63	11.75	12.87	13.99	15.11	16.22	17.33	18.44
		50	10.73	11.88	13.06	14.28	15.53	16.82	18.14	19.50
C-L113M91 805 831 69 11.25kW	Capacity Q (kW)	30	6.45	9.53	13.42	18.14	23.68	30.04	37.21	45.21
		35	5.66	8.39	11.94	16.32	21.52	27.54	34.39	42.06
		40.5	4.88	7.25	10.45	14.48	19.33	25.00	31.50	38.82
		45	4.30	6.41	9.35	13.11	17.68	23.08	29.30	36.34
		50	3.73	5.58	8.24	11.72	16.01	21.12	27.04	33.77
	Input P (kW)	30	6.04	7.18	8.23	9.20	10.08	10.87	11.58	12.20
		35	6.20	7.37	8.48	9.52	10.49	11.39	12.23	13.00
		40.5	6.38	7.58	8.75	9.87	10.96	12.00	13.00	13.97
		45	6.53	7.76	8.97	10.17	11.35	12.52	13.68	14.83
		50	6.70	7.95	9.22	10.51	11.81	13.14	14.48	15.84
	Current A (kW)	30	13.84	15.16	16.45	17.69	18.88	20.04	21.14	22.21
		35	14.03	15.42	16.79	18.15	19.49	20.81	22.11	23.40
		40.5	14.24	15.70	17.18	18.67	20.18	21.70	23.24	24.79
		45	14.42	15.93	17.49	19.10	20.76	22.46	24.21	26.01
		50	14.61	16.19	17.85	19.59	21.42	23.34	25.35	27.44
C-L150M91 805 931 69 15kW	Capacity Q (kW)	30	12.91	15.63	19.88	25.66	32.96	41.79	52.15	64.04
		35	10.70	13.67	17.99	23.64	30.64	38.98	48.66	59.68
		40.5	8.61	11.77	16.10	21.59	28.24	36.05	45.02	55.16
		45	7.16	10.42	14.71	20.04	26.40	33.79	42.22	51.68
		50	5.84	9.13	13.33	18.44	24.47	31.42	39.27	48.04
	Input P (kW)	30	9.18	10.57	11.96	13.35	14.74	16.13	17.52	18.92
		35	9.23	10.77	12.31	13.84	15.37	16.90	18.43	19.95
		40.5	9.27	10.99	12.70	14.41	16.11	17.80	19.49	21.16
		45	9.32	11.19	13.04	14.89	16.74	18.57	20.40	22.21
		50	9.37	11.41	13.44	15.45	17.46	19.47	21.46	23.44
	Current A (kW)	30	20.65	22.41	24.22	26.09	28.02	30.00	32.03	34.12
		35	20.70	22.67	24.71	26.80	28.95	31.16	33.43	35.75
		40.5	20.75	22.97	25.26	27.61	30.02	32.50	35.04	37.65
		45	20.80	23.22	25.72	28.29	30.93	33.64	36.42	39.28
		50	20.85	23.51	26.24	29.07	31.97	34.95	38.02	41.17

R22

Performance Data Power: 50Hz 380V Suction Gas Temp.: 18.3°C
 Subcooling: 0 K Cooling Method: Fan Cooling

Compressor	Item	Condensing Temp.	Evaporating Temp.							
			-40	-35	-30	-25	-20	-15	-10	-5
C-LN15M8A 805 060 68 1.5kW	Capacity Q (kW)	30	1.23	1.31	1.55	1.93	2.46	3.14	3.96	4.93
		35	1.12	1.19	1.39	1.72	2.19	2.79	3.53	4.40
		40.5	1.01	1.06	1.23	1.52	1.92	2.45	3.10	3.87
		45	0.93	0.97	1.11	1.36	1.73	2.20	2.78	3.48
		50	0.85	0.87	0.99	1.21	1.53	1.95	2.47	3.08
	Input P (kW)	30	0.85	0.94	1.03	1.13	1.22	1.31	1.41	1.50
		35	0.87	0.96	1.05	1.14	1.24	1.35	1.46	1.57
		40.5	0.90	0.98	1.06	1.16	1.27	1.38	1.51	1.65
		45	0.92	0.99	1.07	1.17	1.29	1.41	1.56	1.72
		50	0.95	1.01	1.09	1.19	1.31	1.45	1.61	1.80
	Current A (kW)	30	2.11	2.20	2.30	2.41	2.53	2.66	2.80	2.94
		35	2.16	2.24	2.33	2.44	2.57	2.71	2.87	3.04
		40.5	2.22	2.28	2.37	2.48	2.61	2.77	2.95	3.15
		45	2.26	2.32	2.40	2.51	2.65	2.82	3.02	3.24
		50	2.32	2.36	2.44	2.55	2.69	2.88	3.09	3.34
C-LN22M8A 805 047 68 2.2kW	Capacity Q (kW)	30	1.79	1.91	2.25	2.81	3.58	4.56	5.76	7.18
		35	1.63	1.73	2.02	2.50	3.19	4.06	5.14	6.40
		40.5	1.48	1.54	1.79	2.20	2.80	3.57	4.51	5.63
		45	1.36	1.40	1.61	1.98	2.51	3.20	4.05	5.06
		50	1.24	1.27	1.44	1.76	2.22	2.83	3.59	4.49
	Input P (kW)	30	1.19	1.32	1.44	1.57	1.70	1.83	1.97	2.10
		35	1.22	1.34	1.46	1.59	1.73	1.88	2.03	2.19
		40.5	1.26	1.36	1.48	1.62	1.77	1.93	2.11	2.30
		45	1.29	1.38	1.50	1.64	1.80	1.98	2.18	2.40
		50	1.32	1.41	1.52	1.66	1.83	2.03	2.25	2.51
	Current A (kW)	30	2.86	2.98	3.12	3.27	3.43	3.61	3.80	4.00
		35	2.93	3.04	3.17	3.32	3.49	3.68	3.89	4.13
		40.5	3.01	3.10	3.22	3.37	3.55	3.76	4.00	4.27
		45	3.07	3.15	3.26	3.41	3.60	3.83	4.09	4.40
		50	3.15	3.21	3.31	3.46	3.66	3.90	4.20	4.54
C-LN28M8A 805 140 68 2.8kW	Capacity Q (kW)	30	2.49	2.66	3.13	3.91	4.98	6.35	8.02	9.99
		35	2.27	2.41	2.81	3.49	4.44	5.66	7.15	8.92
		40.5	2.06	2.15	2.49	3.07	3.90	4.97	6.28	7.84
		45	1.89	1.96	2.25	2.76	3.49	4.45	5.64	7.04
		50	1.72	1.76	2.00	2.45	3.09	3.94	4.99	6.25
	Input P (kW)	30	1.71	1.90	2.08	2.27	2.46	2.65	2.83	3.03
		35	1.76	1.93	2.11	2.30	2.50	2.71	2.93	3.16
		40.5	1.81	1.97	2.14	2.33	2.55	2.79	3.04	3.32
		45	1.86	2.00	2.16	2.36	2.59	2.85	3.14	3.46
		50	1.91	2.03	2.19	2.39	2.64	2.92	3.25	3.62
	Current A (kW)	30	4.19	4.37	4.57	4.79	5.03	5.29	5.56	5.86
		35	4.29	4.45	4.64	4.86	5.11	5.39	5.70	6.05
		40.5	4.41	4.54	4.72	4.94	5.20	5.51	5.86	6.26
		45	4.50	4.61	4.78	5.00	5.28	5.61	6.00	6.44
		50	4.61	4.70	4.85	5.07	5.36	5.72	6.15	6.65
C-LN37M8A 805 344 68 3.7kW	Capacity Q (kW)	30	2.77	3.98	5.22	6.49	7.79	9.12	10.49	11.88
		35	2.65	3.58	4.61	5.76	7.02	8.39	9.86	11.45
		40.5	2.52	3.17	4.01	5.03	6.24	7.64	9.22	10.99
		45	2.42	2.87	3.56	4.49	5.66	7.07	8.73	10.62
		50	2.32	2.57	3.11	3.94	5.07	6.50	8.21	10.22
	Input P (kW)	30	2.11	2.17	2.32	2.57	2.90	3.33	3.85	4.45
		35	2.08	2.19	2.39	2.68	3.05	3.51	4.05	4.68
		40.5	2.04	2.21	2.47	2.80	3.22	3.71	4.29	4.94
		45	2.01	2.23	2.53	2.91	3.36	3.89	4.49	5.17
		50	1.97	2.26	2.61	3.03	3.53	4.10	4.73	5.44
	Current A (kW)	30	4.86	4.92	5.14	5.54	6.10	6.83	7.73	8.79
		35	4.97	5.09	5.36	5.79	6.35	7.07	7.94	8.95
		40.5	5.10	5.29	5.62	6.07	6.65	7.35	8.18	9.14
		45	5.20	5.47	5.84	6.31	6.90	7.59	8.38	9.29
		50	5.32	5.66	6.09	6.59	7.18	7.86	8.62	9.46

R404A

Semi-Hermetic Reciprocating Compressor For Refrigeration

Performance Data

Power: 50Hz 380V
Subcooling: 0 K

Suction Gas Temp.: 18.3C
Cooling Method: Fan Cooling

Compressor	Item	Condensing Temp.	Evaporating Temp.							
			-40	-35	-30	-25	-20	-15	-10	-5
C-LN45M8A 805 535 68 4.5kW	Capacity Q (kW)	30	3.28	4.71	6.18	7.68	9.22	10.79	12.41	14.06
		35	3.13	4.23	5.46	6.81	8.30	9.92	11.67	13.55
		40.5	2.98	3.75	4.74	5.95	7.38	9.03	10.91	13.00
		45	2.87	3.39	4.21	5.31	6.69	8.37	10.32	12.57
		50	2.74	3.04	3.68	4.67	6.00	7.69	9.72	12.09
	Input P (kW)	30	2.82	2.90	3.11	3.44	3.88	4.45	5.14	5.96
		35	2.78	2.93	3.20	3.58	4.08	4.69	5.42	6.26
		40.5	2.73	2.96	3.30	3.75	4.30	4.97	5.73	6.61
		45	2.68	2.99	3.39	3.89	4.50	5.20	6.01	6.92
		50	2.64	3.02	3.49	4.06	4.72	5.48	6.33	7.27
	Current A (kW)	30	6.54	6.62	6.92	7.45	8.21	9.19	10.40	11.83
		35	6.69	6.85	7.22	7.78	8.55	9.52	10.68	12.05
		40.5	6.86	7.12	7.56	8.17	8.94	9.89	11.01	12.29
		45	7.00	7.35	7.85	8.49	9.28	10.21	11.28	12.50
		50	7.16	7.62	8.19	8.87	9.67	10.57	11.60	12.73
C-LN55M8A 805 445 68 5.5kW	Capacity Q (kW)	30	3.63	5.21	6.83	8.49	10.19	11.94	13.72	15.54
		35	3.46	4.68	6.03	7.53	9.18	10.97	12.90	14.98
		40.5	3.30	4.15	5.24	6.58	8.16	9.99	12.06	14.38
		45	3.17	3.75	4.65	5.87	7.40	9.25	11.42	13.90
		50	3.03	3.36	4.07	5.16	6.64	8.50	10.74	13.37
	Input P (kW)	30	3.11	3.20	3.43	3.79	4.28	4.91	5.67	6.57
		35	3.06	3.23	3.53	3.95	4.50	5.17	5.97	6.90
		40.5	3.01	3.26	3.64	4.13	4.74	5.47	6.32	7.29
		45	2.96	3.29	3.74	4.29	4.96	5.74	6.62	7.62
		50	2.91	3.33	3.85	4.48	5.21	6.04	6.98	8.02
	Current A (kW)	30	7.06	7.15	7.48	8.06	8.87	9.93	11.24	12.78
		35	7.23	7.41	7.80	8.41	9.24	10.29	11.55	13.02
		40.5	7.41	7.70	8.17	8.83	9.67	10.69	11.90	13.29
		45	7.57	7.95	8.49	9.18	10.03	11.03	12.19	13.51
		50	7.74	8.24	8.85	9.59	10.45	11.43	12.53	13.76

R404A

Performance Data

Power: 50Hz 380V
Subcooling: 0 K

Suction Gas Temp.: 18.3°C
Cooling Method: Liquid Injection

Compressor	Item	Condensing Temp.	Evaporating Temp.								
			-40	-35	-30	-25	-20	-15	-10	-5	
C-LN75M81 805 737 68 7.5kW	Capacity Q (kW)	30	0.00	0.00	0.00	0.00	0.00	0.00	0.00	0.00	0.00
		35	0.00	0.00	0.00	0.00	0.00	0.00	0.00	0.00	0.00
		40.5	0.00	0.00	0.00	0.00	0.00	0.00	0.00	0.00	0.00
		45	0.00	0.00	0.00	0.00	0.00	0.00	0.00	0.00	0.00
		50	0.00	0.00	0.00	0.00	0.00	0.00	0.00	0.00	0.00
	Input P (kW)	30	0.00	0.00	0.00	0.00	0.00	0.00	0.00	0.00	0.00
		35	0.00	0.00	0.00	0.00	0.00	0.00	0.00	0.00	0.00
		40.5	0.00	0.00	0.00	0.00	0.00	0.00	0.00	0.00	0.00
		45	0.00	0.00	0.00	0.00	0.00	0.00	0.00	0.00	0.00
		50	0.00	0.00	0.00	0.00	0.00	0.00	0.00	0.00	0.00
	Current A (kW)	30	0.00	0.00	0.00	0.00	0.00	0.00	0.00	0.00	0.00
		35	0.00	0.00	0.00	0.00	0.00	0.00	0.00	0.00	0.00
		40.5	0.00	0.00	0.00	0.00	0.00	0.00	0.00	0.00	0.00
		45	0.00	0.00	0.00	0.00	0.00	0.00	0.00	0.00	0.00
		50	0.00	0.00	0.00	0.00	0.00	0.00	0.00	0.00	0.00
C-LN90M81 805 741 68 9kW	Capacity Q (kW)	30	4.83	7.33	10.44	14.15	18.46	23.38	28.90	35.02	
		35	4.73	6.82	9.50	12.76	16.61	21.03	26.40	31.63	
		40.5	4.61	6.30	8.56	11.37	14.74	18.67	23.16	28.21	
		45	4.51	5.91	7.85	10.33	13.35	16.91	21.01	25.66	
		50	4.40	5.50	7.13	9.27	11.94	15.13	18.84	23.08	
	Input P (kW)	30	5.41	5.97	6.56	7.20	7.86	8.57	9.30	10.08	
		35	5.48	6.10	6.75	7.43	8.15	8.89	9.67	10.49	
		40.5	5.56	6.24	6.96	7.70	8.47	9.27	10.10	10.96	
		45	5.62	6.36	7.13	7.92	8.74	9.59	10.46	11.36	
		50	5.70	6.50	7.33	8.18	9.06	9.96	10.88	11.83	
	Current A (kW)	30	13.21	13.82	14.46	15.13	15.82	16.54	17.29	18.06	
		35	13.26	13.93	14.63	15.37	16.14	16.94	17.78	18.65	
		40.5	13.31	14.05	14.82	15.64	16.50	17.40	18.34	19.33	
		45	13.36	14.14	14.98	15.86	16.80	17.78	18.82	19.90	
		50	13.41	14.25	15.15	16.11	17.14	18.22	19.36	20.56	
C-LN105M81 805 838 68 10.5kW	Capacity Q (kW)	30	5.90	8.96	12.75	17.28	22.55	28.55	35.29	42.77	
		35	5.77	8.33	11.61	15.59	20.28	25.68	31.80	38.62	
		40.5	5.63	7.70	10.45	13.88	18.00	22.80	28.28	34.45	
		45	5.51	7.22	9.58	12.61	16.30	20.65	25.66	31.33	
		50	5.37	6.72	8.70	11.32	14.58	18.48	23.01	28.18	
	Input P (kW)	30	6.50	7.18	7.90	8.66	9.46	10.30	11.19	12.12	
		35	6.59	7.33	8.12	8.94	9.80	10.70	11.63	12.61	
		40.5	6.68	7.51	8.37	9.26	10.19	11.15	12.15	13.18	
		45	6.76	7.65	8.58	9.53	10.52	11.54	12.58	13.66	
		50	6.85	7.82	8.82	9.84	10.90	11.98	13.09	14.22	
	Current A (kW)	30	16.86	17.64	18.45	19.30	20.19	21.10	22.06	23.04	
		35	16.92	17.77	18.67	19.61	20.59	21.62	22.69	23.80	
		40.5	16.99	17.92	18.91	19.95	21.05	22.20	23.41	24.66	
		45	17.04	18.04	19.11	20.24	21.43	22.69	24.01	25.40	
		50	17.10	18.18	19.33	20.56	21.86	23.24	24.70	26.23	
C-LN150M81 805 933 68 15kW	Capacity Q (kW)	30	8.37	12.71	18.09	24.52	31.99	40.51	50.07	60.68	
		35	8.19	11.82	16.47	22.12	28.78	36.44	45.12	54.80	
		40.5	7.99	10.92	14.83	19.70	25.54	32.35	40.13	48.88	
		45	7.82	10.24	13.60	17.89	23.12	29.30	36.41	44.45	
		50	7.62	9.53	12.35	16.07	20.69	26.22	32.65	39.98	
	Input P (kW)	30	9.45	10.43	11.48	12.58	13.75	14.98	16.27	17.62	
		35	9.58	10.66	11.80	12.99	14.24	15.55	16.92	18.33	
		40.5	9.72	10.91	12.16	13.46	14.81	16.21	17.66	19.16	
		45	9.83	11.13	12.47	13.86	15.29	16.77	18.29	19.87	
		50	9.96	11.37	12.82	14.31	15.84	17.42	19.03	20.68	
	Current A (kW)	30	23.31	24.39	25.52	26.69	27.91	29.18	30.50	31.87	
		35	23.40	24.58	25.82	27.12	28.48	29.90	31.37	32.91	
		40.5	23.49	24.78	26.15	27.59	29.11	30.70	32.37	34.11	
		45	23.57	24.95	26.42	27.99	29.64	31.38	33.20	35.12	
		50	23.65	25.14	26.73	28.43	30.23	32.14	34.16	36.28	

R404A

Semi-Hermetic Reciprocating Compressor For Refrigeration

Performance Data

Power: 60Hz 440V
Subcooling: 0 K

Suction Gas Temp.: 18.3°C
Cooling Method: Fan Cooling

Compressor	Item	Condensing Temp.	Evaporating Temp.							
			-40	-35	-30	-25	-20	-15	-10	-5
C-LN15M8A 805 060 68 1.5kW	Capacity Q (kW)	30	1.08	1.23	1.55	2.05	2.73	3.58	4.61	5.82
		35	1.03	1.15	1.43	1.87	2.47	3.22	4.14	5.21
		40.5	0.98	1.07	1.31	1.68	2.20	2.86	3.66	4.61
		45	0.94	1.01	1.21	1.54	2.00	2.59	3.31	4.16
		50	0.89	0.94	1.11	1.40	1.80	2.32	2.96	3.71
	Input P (kW)	30	0.88	0.99	1.11	1.23	1.35	1.48	1.61	1.75
		35	0.89	1.01	1.13	1.25	1.38	1.52	1.66	1.81
		40.5	0.90	1.02	1.15	1.28	1.42	1.56	1.71	1.87
		45	0.91	1.03	1.16	1.30	1.45	1.60	1.76	1.93
		50	0.92	1.05	1.18	1.33	1.48	1.64	1.81	1.99
	Current A (kW)	30	2.04	2.15	2.27	2.41	2.57	2.74	2.93	3.13
		35	2.02	2.15	2.29	2.44	2.61	2.79	2.99	3.20
		40.5	2.00	2.15	2.30	2.47	2.65	2.85	3.06	3.29
		45	1.99	2.14	2.31	2.49	2.69	2.90	3.12	3.36
		50	1.97	2.14	2.32	2.52	2.73	2.95	3.19	3.44
C-LN22M8A 805 047 68 2.2kW	Capacity Q (kW)	30	1.55	1.76	2.22	2.93	3.89	5.11	6.58	8.30
		35	1.47	1.64	2.04	2.67	3.52	4.60	5.90	7.44
		40.5	1.40	1.53	1.86	2.40	3.14	4.08	5.23	6.58
		45	1.34	1.44	1.73	2.20	2.85	3.70	4.72	5.93
		50	1.28	1.35	1.59	1.99	2.57	3.31	4.22	5.29
	Input P (kW)	30	1.26	1.42	1.59	1.76	1.94	2.13	2.32	2.51
		35	1.28	1.44	1.62	1.80	1.98	2.18	2.38	2.60
		40.5	1.30	1.47	1.65	1.83	2.03	2.24	2.46	2.69
		45	1.31	1.48	1.67	1.87	2.07	2.29	2.52	2.77
		50	1.33	1.51	1.70	1.90	2.12	2.35	2.60	2.86
	Current A (kW)	30	2.76	2.91	3.08	3.27	3.48	3.71	3.96	4.24
		35	2.74	2.91	3.10	3.31	3.53	3.78	4.05	4.34
		40.5	2.71	2.91	3.11	3.34	3.59	3.86	4.15	4.45
		45	2.69	2.90	3.13	3.38	3.64	3.93	4.23	4.55
		50	2.67	2.90	3.15	3.41	3.70	4.00	4.32	4.66
C-LN28M8A 805 140 68 2.8kW	Capacity Q (kW)	30	2.19	2.48	3.14	4.15	5.51	7.23	9.31	11.74
		35	2.09	2.33	2.89	3.77	4.98	6.51	8.35	10.52
		40.5	1.98	2.16	2.64	3.39	4.44	5.78	7.40	9.30
		45	1.89	2.04	2.44	3.11	4.04	5.23	6.68	8.40
		50	1.81	1.91	2.25	2.82	3.63	4.68	5.97	7.49
	Input P (kW)	30	1.95	2.20	2.46	2.72	3.00	3.29	3.58	3.89
		35	1.98	2.23	2.50	2.78	3.07	3.37	3.69	4.01
		40.5	2.00	2.27	2.54	2.83	3.14	3.47	3.80	4.16
		45	2.03	2.29	2.58	2.88	3.21	3.55	3.90	4.28
		50	2.05	2.33	2.62	2.94	3.28	3.64	4.02	4.42
	Current A (kW)	30	4.09	4.31	4.56	4.84	5.15	5.49	5.86	6.27
		35	4.05	4.30	4.58	4.89	5.23	5.59	5.99	6.42
		40.5	4.02	4.30	4.61	4.95	5.31	5.71	6.13	6.59
		45	3.99	4.29	4.63	4.99	5.39	5.81	6.25	6.73
		50	3.95	4.29	4.65	5.05	5.47	5.92	6.39	6.89
C-LN37M8A 805 344 68 3.7kW	Capacity Q (kW)	30	3.37	4.79	6.16	7.50	8.78	10.03	11.23	12.39
		35	3.22	4.38	5.57	6.79	8.04	9.31	10.62	11.95
		40.5	3.06	3.97	4.97	6.08	7.28	8.58	9.98	11.48
		45	2.94	3.66	4.52	5.54	6.70	8.02	9.48	11.10
		50	2.81	3.34	4.06	4.99	6.12	7.44	8.97	10.69
	Input P (kW)	30	2.42	2.63	2.87	3.14	3.44	3.78	4.14	4.54
		35	2.39	2.69	3.00	3.32	3.65	3.99	4.35	4.71
		40.5	2.35	2.76	3.15	3.53	3.90	4.25	4.59	4.91
		45	2.32	2.82	3.29	3.72	4.11	4.47	4.79	5.08
		50	2.28	2.89	3.45	3.94	4.36	4.73	5.03	5.27
	Current A (kW)	30	5.29	5.41	5.67	6.07	6.60	7.26	8.06	9.00
		35	5.38	5.47	5.72	6.13	6.69	7.42	8.31	9.35
		40.5	5.48	5.53	5.77	6.19	6.80	7.60	8.58	9.75
		45	5.56	5.58	5.81	6.25	6.89	7.75	8.82	10.10
		50	5.66	5.64	5.85	6.31	7.00	7.92	9.09	10.49

R404A

Performance Data

Power: 60Hz 440V
Subcooling: 0 KSuction Gas Temp.: 18.3°C
Cooling Method: Fan Cooling

Compressor	Item	Condensing Temp.	Evaporating Temp.							
			-40	-35	-30	-25	-20	-15	-10	-5
C-LN45M8A 805 535 68 4.5kW	Capacity Q (kW)	30	3.90	5.54	7.13	8.67	10.17	11.61	13.00	14.34
		35	3.73	5.07	6.45	7.86	9.30	10.78	12.29	13.83
		40.5	3.54	4.59	5.75	7.03	8.42	9.93	11.55	13.28
		45	3.40	4.23	5.23	6.41	7.76	9.28	10.98	12.84
		50	3.25	3.86	4.70	5.78	7.08	8.61	10.38	12.37
	Input P (kW)	30	3.51	3.80	4.15	4.54	4.98	5.46	6.00	6.57
		35	3.46	3.89	4.34	4.80	5.28	5.78	6.29	6.82
		40.5	3.40	3.99	4.56	5.11	5.64	6.15	6.64	7.10
		45	3.36	4.08	4.76	5.38	5.95	6.47	6.93	7.35
		50	3.30	4.19	4.99	5.69	6.31	6.84	7.28	7.63
	Current A (kW)	30	7.14	7.31	7.66	8.19	8.91	9.81	10.89	12.15
		35	7.26	7.38	7.72	8.27	9.04	10.02	11.21	12.63
		40.5	7.39	7.46	7.79	8.36	9.18	10.26	11.59	13.17
		45	7.51	7.53	7.84	8.43	9.31	10.46	11.90	13.63
		50	7.64	7.61	7.90	8.51	9.44	10.70	12.27	14.16
C-LN55M8A 805 445 68 5.5kW	Capacity Q (kW)	30	4.45	6.33	8.14	9.90	11.60	13.25	14.83	16.36
		35	4.25	5.79	7.36	8.97	10.62	12.30	14.02	15.78
		40.5	4.04	5.24	6.57	8.02	9.61	11.33	13.18	15.16
		45	3.88	4.83	5.97	7.31	8.85	10.59	12.53	14.66
		50	3.71	4.41	5.37	6.59	8.08	9.83	11.84	14.12
	Input P (kW)	30	3.75	4.07	4.44	4.85	5.32	5.84	6.41	7.03
		35	3.70	4.16	4.64	5.13	5.65	6.18	6.73	7.29
		40.5	3.64	4.27	4.88	5.46	6.03	6.57	7.09	7.59
		45	3.59	4.36	5.09	5.75	6.36	6.91	7.41	7.85
		50	3.53	4.48	5.33	6.09	6.75	7.31	7.78	8.15
	Current A (kW)	30	7.63	7.81	8.18	8.75	9.51	10.47	11.63	12.98
		35	7.75	7.89	8.25	8.83	9.65	10.70	11.98	13.49
		40.5	7.90	7.97	8.32	8.93	9.81	10.96	12.38	14.07
		45	8.02	8.05	8.38	9.01	9.94	11.18	12.72	14.56
		50	8.16	8.13	8.44	9.09	10.09	11.42	13.10	15.12

R404A

Semi-Hermetic Reciprocating Compressor For Refrigeration

60Hz 440V

Performance Data

Power: 60Hz 440V

Suction Gas Temp.: 18.3°C

Subcooling: 0 K

Cooling Method: Liquid Injection

Compressor	Item	Condensing Temp.	Evaporating Temp.								
			-40	-35	-30	-25	-20	-15	-10	-5	
C-LN75M81 805 737 68 7.5kW	Capacity Q (kW)	30	0.00	0.00	0.00	0.00	0.00	0.00	0.00	0.00	0.00
		35	0.00	0.00	0.00	0.00	0.00	0.00	0.00	0.00	0.00
		40.5	0.00	0.00	0.00	0.00	0.00	0.00	0.00	0.00	0.00
		45	0.00	0.00	0.00	0.00	0.00	0.00	0.00	0.00	0.00
		50	0.00	0.00	0.00	0.00	0.00	0.00	0.00	0.00	0.00
	Input P (kW)	30	0.00	0.00	0.00	0.00	0.00	0.00	0.00	0.00	0.00
		35	0.00	0.00	0.00	0.00	0.00	0.00	0.00	0.00	0.00
		40.5	0.00	0.00	0.00	0.00	0.00	0.00	0.00	0.00	0.00
		45	0.00	0.00	0.00	0.00	0.00	0.00	0.00	0.00	0.00
		50	0.00	0.00	0.00	0.00	0.00	0.00	0.00	0.00	0.00
	Current A (kW)	30	0.00	0.00	0.00	0.00	0.00	0.00	0.00	0.00	0.00
		35	0.00	0.00	0.00	0.00	0.00	0.00	0.00	0.00	0.00
		40.5	0.00	0.00	0.00	0.00	0.00	0.00	0.00	0.00	0.00
		45	0.00	0.00	0.00	0.00	0.00	0.00	0.00	0.00	0.00
		50	0.00	0.00	0.00	0.00	0.00	0.00	0.00	0.00	0.00
	C-LN90M81 805 741 68 9kW	Capacity Q (kW)	30	6.52	9.42	12.82	16.71	21.10	25.98	31.35	37.21
35			5.63	8.22	11.31	14.90	19.00	23.60	28.71	34.33	
40.5			4.77	7.03	9.80	13.09	16.89	21.20	26.03	31.37	
45			4.15	6.16	8.69	11.74	15.31	19.40	24.00	29.12	
50			3.54	5.31	7.60	10.40	13.72	17.57	21.92	26.80	
Input P (kW)		30	6.16	7.14	8.10	9.01	9.89	10.73	11.53	12.30	
		35	5.94	7.04	8.11	9.13	10.12	11.07	11.99	12.87	
		40.5	5.71	6.93	8.12	9.27	10.39	11.47	12.52	13.53	
		45	5.52	6.84	8.13	9.39	10.61	11.80	12.96	14.09	
		50	5.33	6.75	8.14	9.52	10.86	12.18	13.48	14.75	
Current A (kW)		30	13.04	13.92	14.82	15.73	16.66	17.60	18.56	19.54	
		35	12.80	13.81	14.83	15.87	16.93	18.01	19.11	20.23	
		40.5	12.55	13.69	14.84	16.03	17.24	18.47	19.73	21.02	
		45	12.35	13.59	14.86	16.16	17.49	18.85	20.25	21.69	
		50	12.13	13.48	14.87	16.30	17.77	19.29	20.85	22.46	
C-LN105M81 805 838 68 10.5kW		Capacity Q (kW)	30	9.03	11.57	14.82	19.00	24.35	31.20	39.99	51.25
	35		7.80	10.11	13.10	16.98	22.00	28.51	36.94	47.87	
	40.5		6.64	8.71	11.43	14.99	19.67	25.80	33.84	44.40	
	45		5.82	7.71	10.22	13.54	17.94	23.77	31.50	41.73	
	50		5.03	6.74	9.02	12.09	16.20	21.70	29.07	38.95	
	Input P (kW)	30	7.10	8.27	9.40	10.48	11.52	12.52	13.47	14.38	
		35	7.08	8.32	9.52	10.71	11.87	13.01	14.12	15.21	
		40.5	7.06	8.36	9.66	10.96	12.27	13.57	14.87	16.18	
		45	7.05	8.40	9.78	11.18	12.60	14.05	15.52	17.02	
		50	7.04	8.44	9.90	11.42	12.99	14.61	16.28	18.01	
	Current A (kW)	30	16.72	17.71	18.72	19.75	20.80	21.88	22.98	24.11	
		35	16.70	17.74	18.84	19.98	21.19	22.44	23.75	25.12	
		40.5	16.68	17.78	18.97	20.25	21.62	23.08	24.63	26.28	
		45	16.67	17.81	19.07	20.46	21.98	23.62	25.38	27.27	
		50	16.66	17.84	19.19	20.70	22.38	24.23	26.24	28.42	
	C-LN150M81 805 933 68 15kW	Capacity Q (kW)	30	12.34	16.47	21.61	27.79	34.98	43.21	52.46	62.74
35			10.73	14.64	19.49	25.29	32.05	39.74	48.39	57.98	
40.5			9.14	12.81	17.36	22.77	29.05	36.20	44.22	53.11	
45			7.98	11.47	15.76	20.87	26.78	33.51	41.05	49.40	
50			6.86	10.13	14.16	18.93	24.46	30.74	37.78	45.56	
Input P (kW)		30	10.12	11.68	13.27	14.90	16.56	18.26	19.99	21.75	
		35	10.11	11.82	13.55	15.32	17.11	18.93	20.79	22.67	
		40.5	10.11	11.98	13.87	15.79	17.74	19.71	21.71	23.74	
		45	10.10	12.11	14.13	16.19	18.27	20.37	22.50	24.65	
		50	10.10	12.25	14.44	16.64	18.87	21.13	23.40	25.70	
Current A (kW)		30	21.75	23.10	24.59	26.23	28.01	29.93	31.99	34.20	
		35	21.74	23.24	24.89	26.68	28.62	30.70	32.93	35.30	
		40.5	21.72	23.39	25.22	27.19	29.30	31.57	33.98	36.55	
		45	21.71	23.52	25.49	27.61	29.88	32.30	34.88	37.61	
		50	21.70	23.67	25.79	28.08	30.53	33.13	35.90	38.82	

R404A

Performance Data

Power: 60Hz 380V

Suction Gas Temp.: 18.3°C

Subcooling: 0 K

Cooling Method: Liquid Injection

Compressor	Item	Condensing Temp.	Evaporating Temp.							
			-40	-35	-30	-25	-20	-15	-10	-5
C-LN75M91 805 737 69 7.5kW	Capacity Q (kW)	30	7.70	9.50	12.00	15.21	19.13	23.76	29.10	35.15
		35	5.76	7.78	10.38	13.55	17.29	21.61	26.50	31.97
		40.5	4.04	6.20	8.82	11.89	15.42	19.40	23.84	28.73
		45	2.95	5.14	7.71	10.67	14.00	17.71	21.80	26.28
		50	2.07	4.21	6.67	9.45	12.55	15.96	19.70	23.76
	Input P (kW)	30	5.07	5.98	6.82	7.61	8.32	8.98	9.56	10.09
		35	4.84	5.89	6.86	7.76	8.59	9.34	10.02	10.62
		40.5	4.60	5.80	6.91	7.94	8.88	9.75	10.54	11.24
		45	4.43	5.73	6.95	8.08	9.13	10.10	10.98	11.77
		50	4.24	5.67	7.00	8.25	9.42	10.50	11.49	12.39
	Current A (kW)	30	10.88	12.07	13.19	14.25	15.23	16.15	17.00	17.78
		35	10.66	11.98	13.25	14.45	15.60	16.69	17.71	18.68
		40.5	10.42	11.88	13.31	14.68	16.01	17.30	18.54	19.74
		45	10.23	11.80	13.35	14.87	16.36	17.82	19.25	20.66
		50	10.01	11.71	13.40	15.08	16.75	18.42	20.07	21.72
	C-LN113M91 805 838 69 11.25kW	Capacity Q (kW)	30	9.21	12.71	16.88	21.72	27.22	33.39	40.23
35			7.75	10.94	14.78	19.30	24.47	30.31	36.82	43.99
40.5			6.35	9.20	12.71	16.88	21.71	27.20	33.35	40.17
45			5.35	7.94	11.19	15.09	19.65	24.86	30.74	37.26
50			4.40	6.72	9.69	13.31	17.58	22.49	28.06	34.27
Input P (kW)		30	6.97	8.19	9.37	10.50	11.58	12.62	13.61	14.56
		35	6.88	8.20	9.49	10.74	11.95	13.12	14.26	15.35
		40.5	6.77	8.21	9.62	11.01	12.37	13.70	15.01	16.29
		45	6.69	8.22	9.73	11.23	12.72	14.19	15.65	17.09
		50	6.60	8.23	9.86	11.49	13.12	14.76	16.40	18.04
Current A (kW)		30	15.35	16.87	18.41	19.95	21.50	23.06	24.63	26.20
		35	15.23	16.89	18.57	20.29	22.04	23.82	25.63	27.47
		40.5	15.09	16.89	18.76	20.68	22.66	24.70	26.80	28.96
		45	14.98	16.90	18.90	20.99	23.17	25.44	27.80	30.25
		50	14.86	16.90	19.06	21.35	23.76	26.30	28.96	31.75
C-LN150M91 805 933 69 15kW		Capacity Q (kW)	30	14.01	18.98	24.96	31.95	39.95	48.97	59.00
	35		12.09	16.70	22.26	28.76	36.22	44.62	53.97	64.27
	40.5		10.22	14.45	19.56	25.55	32.43	40.20	48.85	58.38
	45		8.87	12.80	17.56	23.16	29.60	36.87	44.98	53.93
	50		7.56	11.17	15.57	20.75	26.72	33.48	41.03	49.36
	Input P (kW)	30	10.33	11.87	13.43	15.03	16.65	18.29	19.97	21.68
		35	10.34	12.02	13.74	15.49	17.29	19.13	21.01	22.93
		40.5	10.35	12.18	14.08	16.03	18.03	20.10	22.22	24.40
		45	10.35	12.32	14.36	16.48	18.67	20.93	23.27	25.68
		50	10.36	12.47	14.68	16.99	19.40	21.90	24.50	27.19
	Current A (kW)	30	21.86	23.97	26.14	28.35	30.62	32.95	35.33	37.76
		35	21.94	24.20	26.57	29.03	31.60	34.27	37.04	39.92
		40.5	22.03	24.45	27.04	29.79	32.71	35.80	39.05	42.47
		45	22.09	24.65	27.43	30.43	33.66	37.11	40.79	44.69
		50	22.16	24.86	27.86	31.16	34.75	38.64	42.82	47.30

R404A

Outline Graph

C-L1 2HP

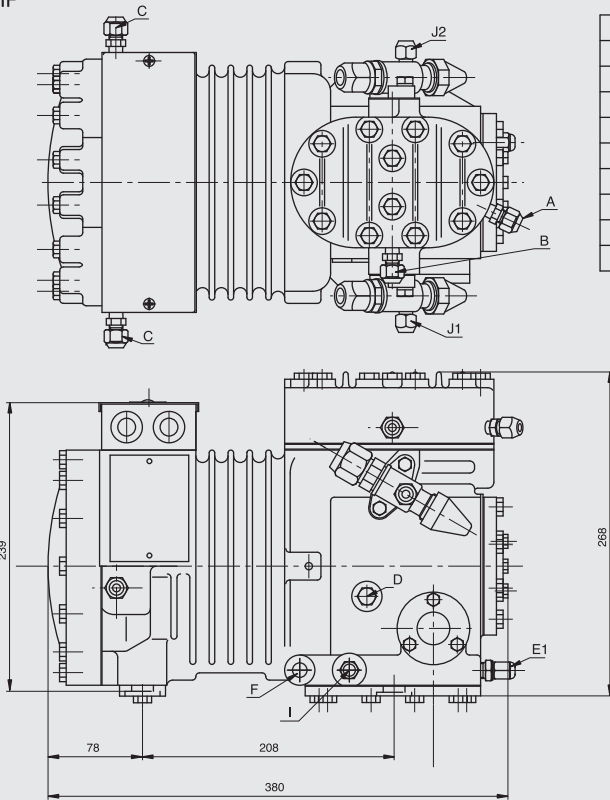

Code	Name	Dimension
A	high pressure connector	7/16-20UNF
B	Low pressure connector	7/16-20UNF
C	Liquid injection cooling inlet	7/16-20UNF
D	Oil inlet valve	7/16-20UNF
E1	Oil check valve #1	7/16-20UNF
F	Crankcase heater assy	PT3/8
I	Heater fastness screw	-
J1	Suction service valve	7/16-20UNF
J2	Discharge service valve	7/16-20UNF

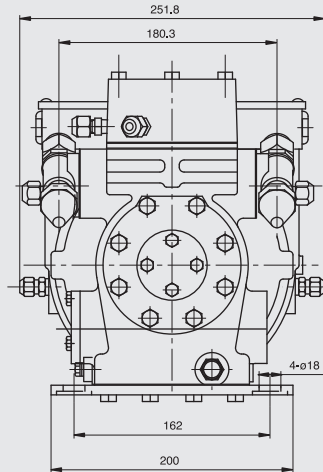

R22
R404A

C-L1 3HP

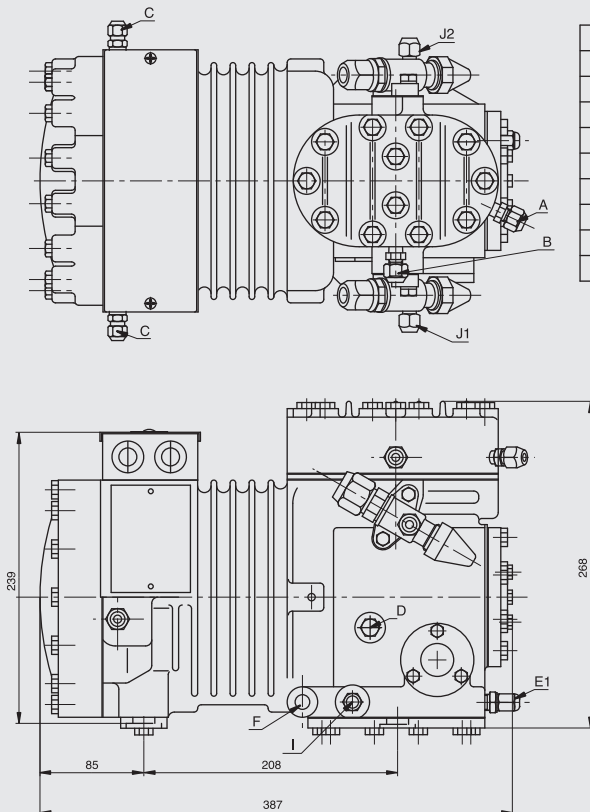

Code	Name	Dimension
A	high pressure connector	7/16-20UNF
B	Low pressure connector	7/16-20UNF
C	Liquid injection cooling inlet	7/16-20UNF
D	Oil inlet valve	7/16-20UNF
E1	Oil check valve #1	7/16-20UNF
F	Crankcase heater assy	PT3/8
I	Heater fastness screw	-
J1	Suction service valve	7/16-20UNF
J2	Discharge service valve	7/16-20UNF

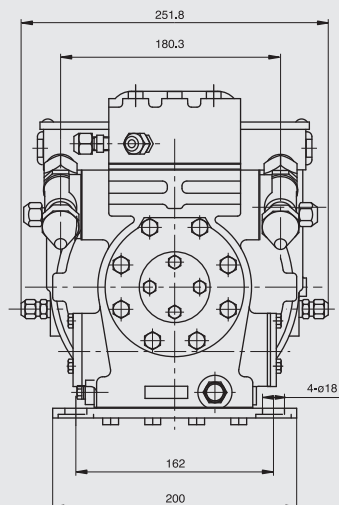

Outline Graph

C-L2 4HP/5HP

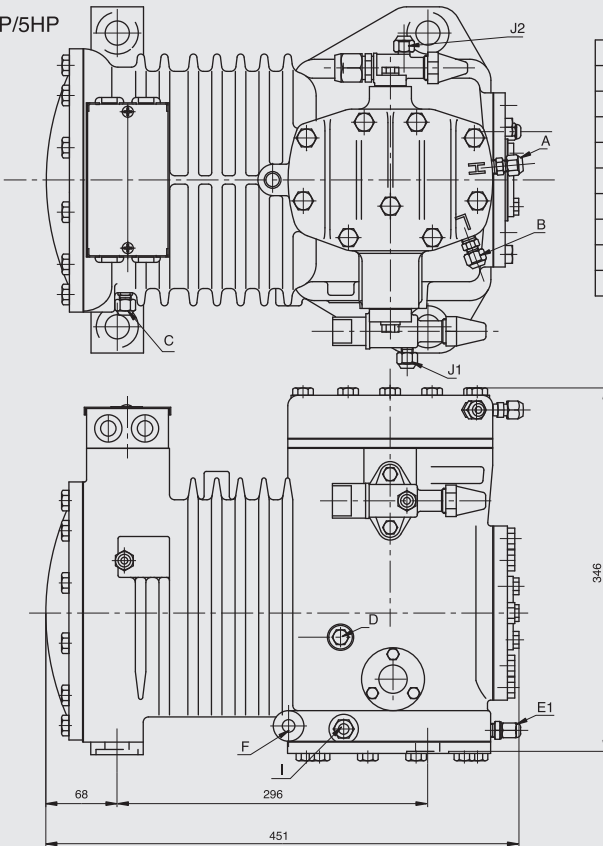

Code	Name	Dimension
A	high pressure connector	7/16-20UNF
B	Low pressure connector	7/16-20UNF
C	Liquid injection cooling inlet	7/16-20UNF
D	Oil inlet valve	7/16-20UNF
E1	Oil check valve #1	7/16-20UNF
F	Crankcase heater assy	PT3/8
I	Heater fastness screw	-
J1	Suction service valve	7/16-20UNF
J2	Discharge service valve	7/16-20UNF

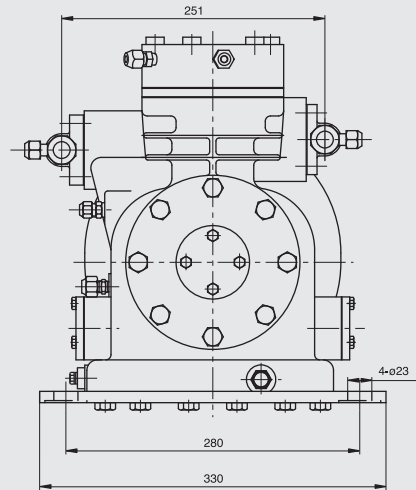

R22
R404A

C-L2 6HP

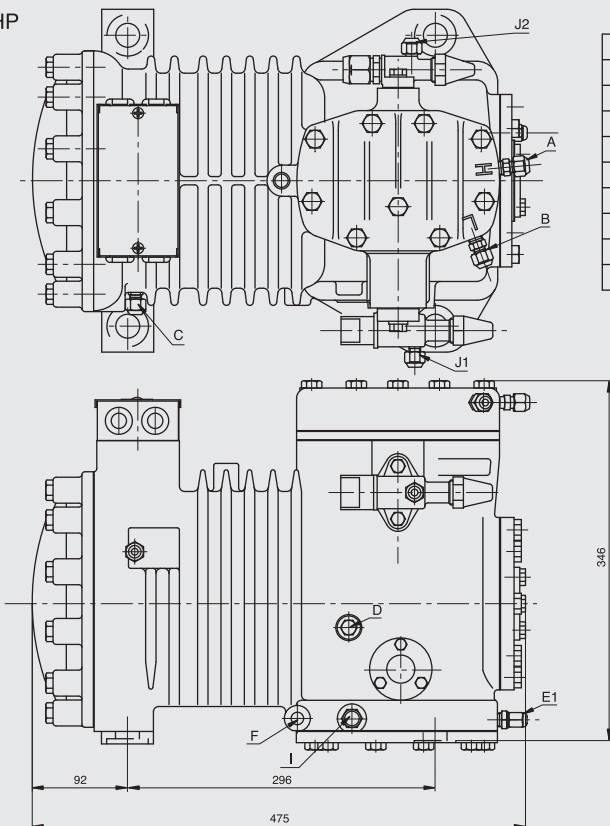

Code	Name	Dimension
A	high pressure connector	7/16-20UNF
B	Low pressure connector	7/16-20UNF
C	Liquid injection cooling inlet	7/16-20UNF
D	Oil inlet valve	7/16-20UNF
E1	Oil check valve #1	7/16-20UNF
F	Crankcase heater assy	PT3/8
I	Heater fastness screw	-
J1	Suction service valve	7/16-20UNF
J2	Discharge service valve	7/16-20UNF

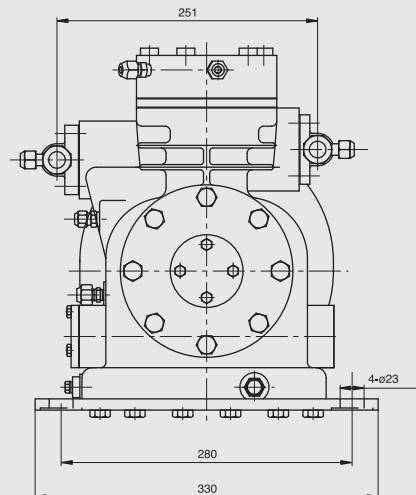

Outline Graph

C-L2 7.5HP

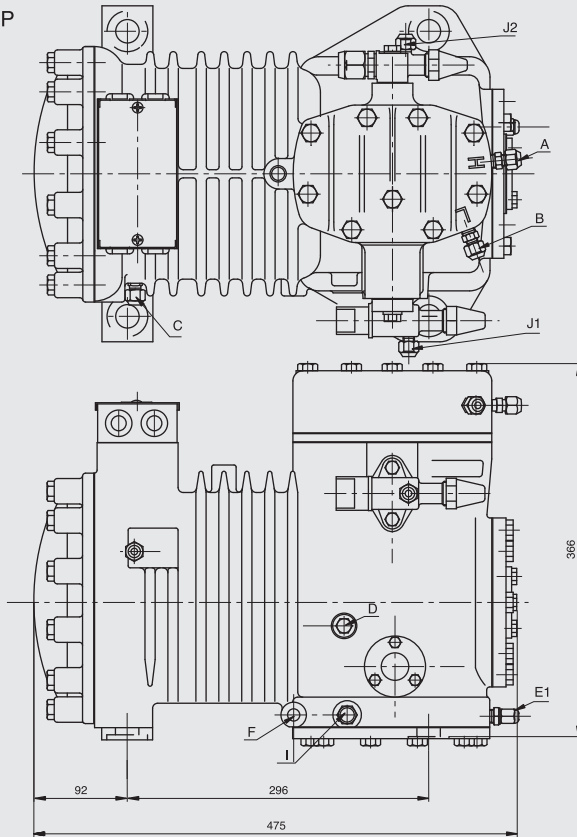

Code	Name	Dimension
A	high pressure connector	7/16-20UNF
B	Low pressure connector	7/16-20UNF
C	Liquid injection cooling inlet	7/16-20UNF
D	Oil inlet valve	7/16-20UNF
E1	Oil check valve #1	7/16-20UNF
F	Crankcase heater assy	PT3/8
I	Heater fastness screw	-
J1	Suction service valve	7/16-20UNF
J2	Discharge service valve	7/16-20UNF

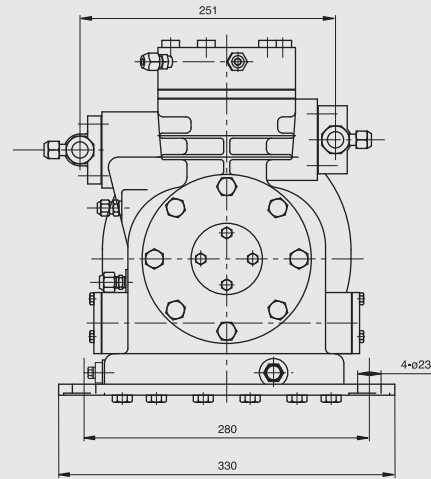

R22
R404A

Outline Graph

C-L3 10HP/12.5HP

Code	Name	Dimension
A	high pressure connector	7/16-20UNF
B	Low pressure connector	7/16-20UNF
C	Liquid injection cooling inlet	7/16-20UNF
D	Oil inlet valve	7/16-20UNF
E1	Oil check valve #1	7/16-20UNF
F	Crankcase heater assy	PT3/8
I	Heater fastness screw	-
J1	Suction service valve	7/16-20UNF
J2	Discharge service valve	7/16-20UNF

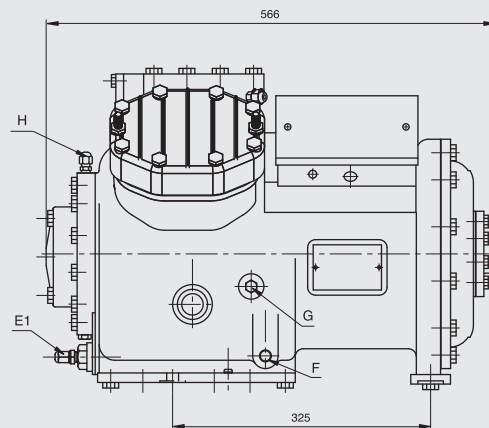
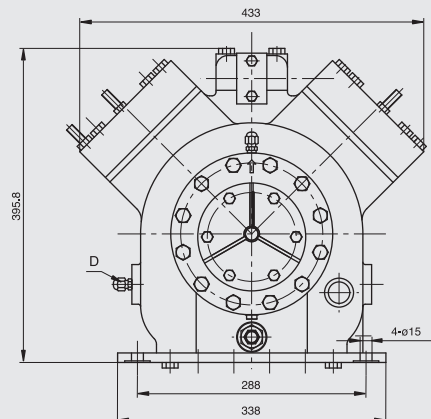
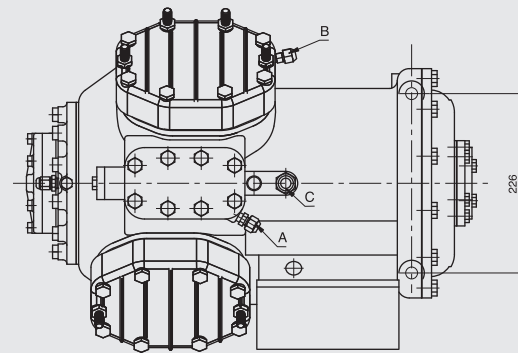

Outline Graph

C-L3 15HP

Code	Name	Dimension
A	high pressure connector	7/16-20UNF
B	Low pressure connector	7/16-20UNF
C	Liquid injection cooling inlet	7/16-20UNF
D	Oil inlet valve	7/16-20UNF
E1	Oil check valve #1	7/16-20UNF
F	Crankcase heater assy	PT3/8
G	Screw shutoff	PT1/4
H	Oil pressure connector	7/16-20UNF

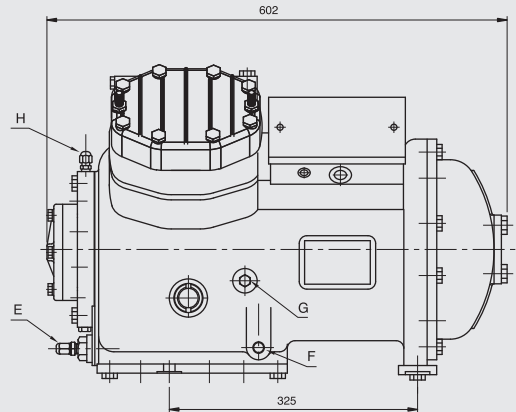
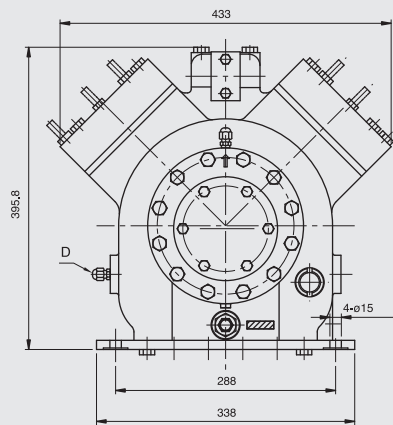
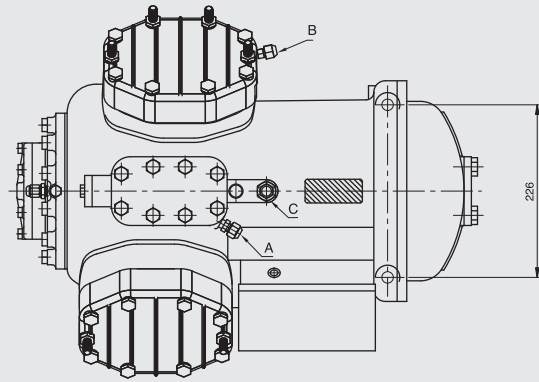

R22
R404A

C-L3 20HP

Code	Name	Dimension
A	high pressure connector	7/16-20UNF
B	Low pressure connector	7/16-20UNF
C	Liquid injection cooling inlet	7/16-20UNF
D	Oil inlet valve	7/16-20UNF
E1	Oil check valve #1	7/16-20UNF
F	Crankcase heater assy	PT3/8
G	Screw shutoff	PT1/4
H	Oil pressure connector	7/16-20UNF

